

19'-9" 34
 19'-3" 33
 18'-9" 32
 18'-3" 31
 17'-9" 30
 17'-3" 29
 16'-9" 28
 16'-3" 27
 15'-9" 26
 15'-3" 25
 14'-9" 24
 14'-3" 23
 13'-9" 22
 13'-3" 21
 12'-9" 20
 12'-3" 19
 11'-9" 18
 11'-3" 17
 10'-9" 16
 10'-3" 15
 9'-9" 14
 9'-3" 13
 8'-9" 12
 8'-3" 11
 7'-9" 10
 7'-3" 9
 6'-9" 8
 6'-3" 7
 5'-9" 6

4'-4" 5
 3'-10" 4
 3'-4" 3
 2'-10" 2

1'-3" 1

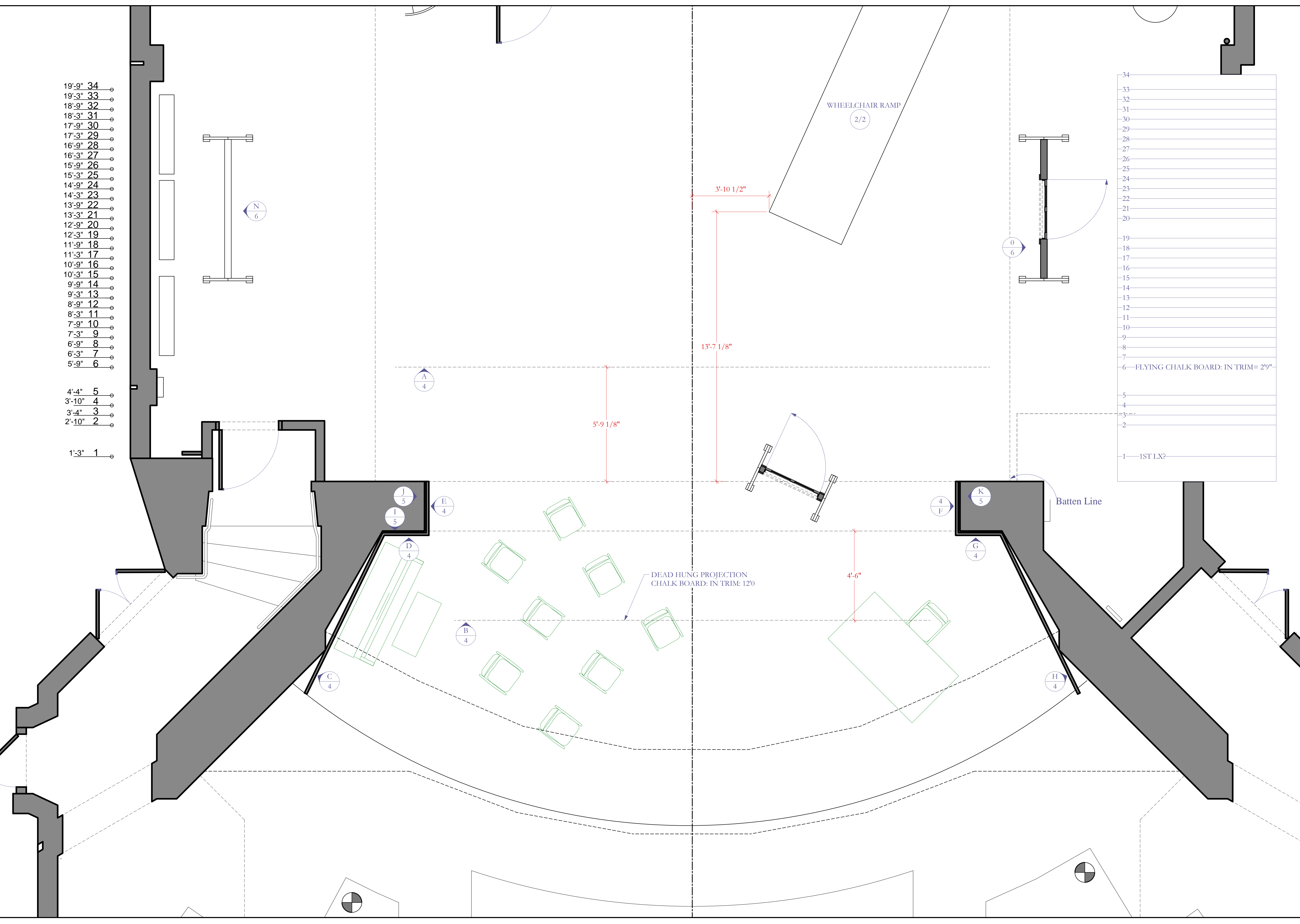

34
33
32
31
30
29
28
27
26
25
24
23
22
21
20
19
18
17
16
15
14
13
12
11
10
9
8
7
6
5
4
3
2
1

FLYING CHALK BOARD: IN TRIM= 2'9"

1ST LX?

THE HISTORY BOYS
 PITTSBURGH IRISH AND CLASSICAL THEATRE, ARTISTIC DIRECTOR: ANDREW PAUL
 DIRECTED BY ANDREW PAUL, PRODUCTION MANAGER: PHIL MADORE, TECHNICAL DIRECTOR: PAUL BISTRICAN

DESIGNER: GIANNI DOWNS 412-779-7498
 GIANNIDOWNS@GMAIL.COM
 WWW.GIANNIDESIGNS.NET

DRAFTED: JULY 2, 2009
 REVISED ON: JULY 7, 2009

SCALE: 1/2"=1'-0"

PLATE:
1
 OF 7

19'-9" 34
 19'-3" 33
 18'-9" 32
 18'-3" 31
 17'-9" 30
 17'-3" 29
 16'-9" 28
 16'-3" 27
 15'-9" 26
 15'-3" 25
 14'-9" 24
 14'-3" 23
 13'-9" 22
 13'-3" 21
 12'-9" 20
 12'-3" 19
 11'-9" 18
 11'-3" 17
 10'-9" 16
 10'-3" 15
 9'-9" 14
 9'-3" 13
 8'-9" 12

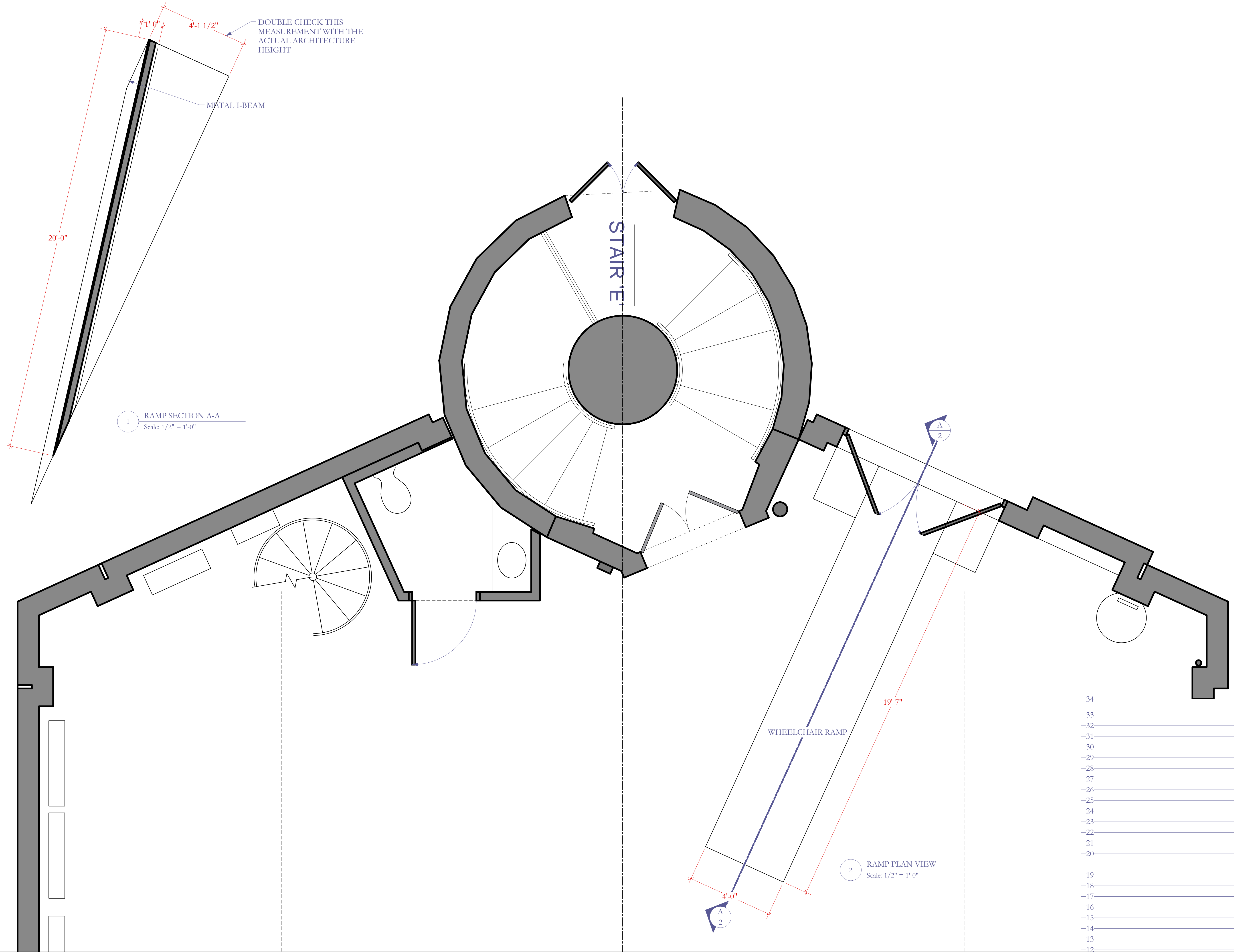

1 RAMP SECTION A-A
 Scale: 1/2" = 1'-0"

2 RAMP PLAN VIEW
 Scale: 1/2" = 1'-0"

DESIGNER: GIANNI DOWNS 412-779-7498
 GIANNIDOWNS@GMAIL.COM
 WWW.GIANNIDESIGNS.NET

DRAFTED: JULY 2, 2009
 REVISED ON: JULY 7, 2009

PLATE:

2

OF 7

THE HISTORY BOYS
 PITTSBURGH IRISH AND CLASSICAL THEATRE ARTISTIC DIRECTOR: ANDREW PAUL
 DIRECTED BY ANDREW PAUL, PRODUCTIONS MANAGER: PHIL MADORE, TECHNICAL DIRECTOR: PAUL BISTRICAN

1/2" GROUND PLAN UPSTAGE AREAS
 SCALE: 1/2" = 1'-0"

27
26
25
24
23
22
21
20
19
18
17
16
15
14
13
12
11
10
9
8
7
6
5
4
3
2
1

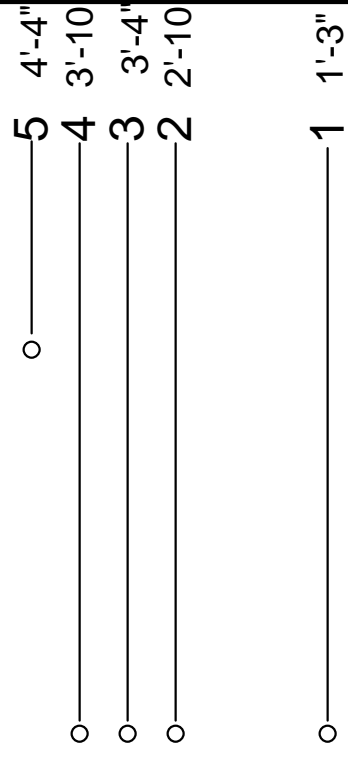
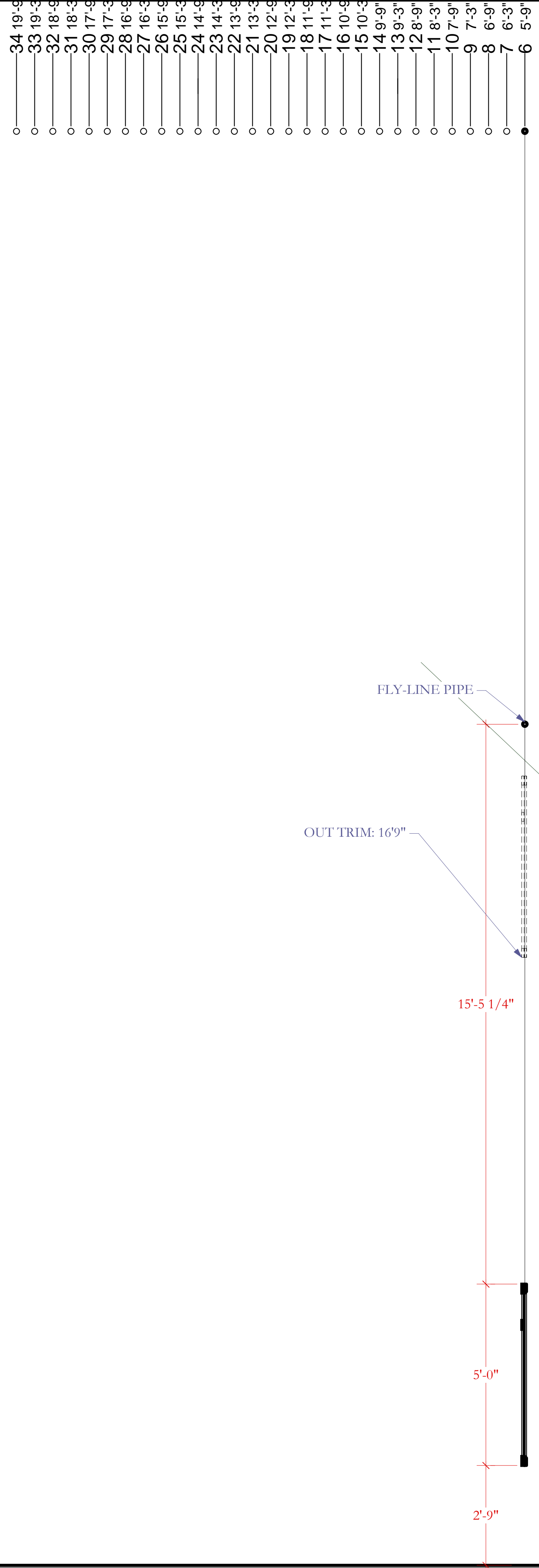

FLY-LINE PIPE

OUT TRIM: 16"9"

DOUBLE CHECK THIS HEIGHT MEASUREMENT AT THEATRE

15'-5 1/4"

5'-0"

5'-0"

2'-9"

11'-0"

5'-0"

2'-9"

27
26
25
24
23
22
21
20
19
18
17
16
15
14
13
12
11
10
9
8
7
6
5
4
3
2
1

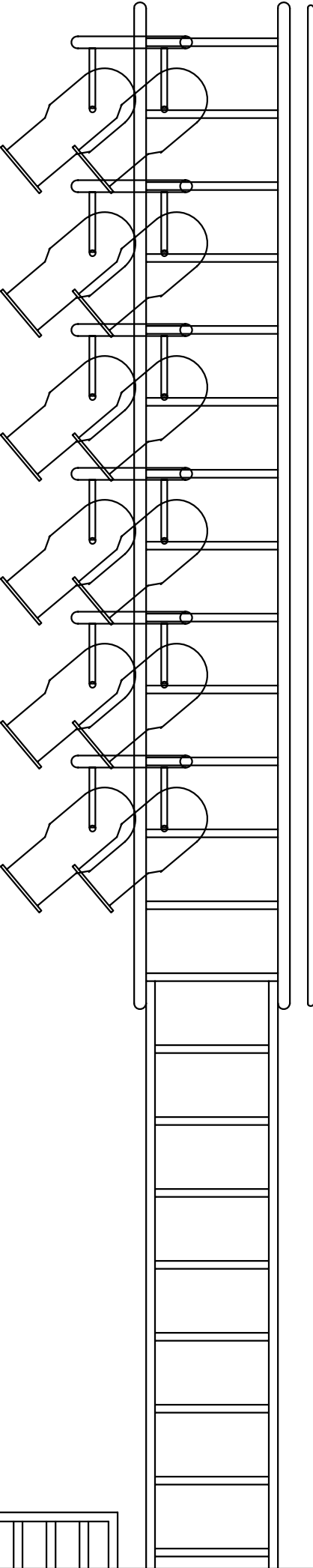

THE HISTORY BOYS
PITTSBURGH IRISH AND CLASSICAL THEATRE, ARTISTIC DIRECTOR: ANDREW PAUL
DIRECTED BY ANDREW PAUL, PRODUCTION MANAGER: PHIL MADORE, TECHNICAL DIRECTOR: PAUL BISTRICAN

DESIGNER: GIANNI DOWNS 412-779-7498
GIANNIDOWNS@GMAIL.COM
WWW.GIANNIDESIGNS.NET

DRAFTED: JULY 2, 2009
REVISED ON: JULY 7, 2009

PLATE:

3

OF 7

1/2" CENTERLINE SECTION

SCALE 1/2"=1'-0"

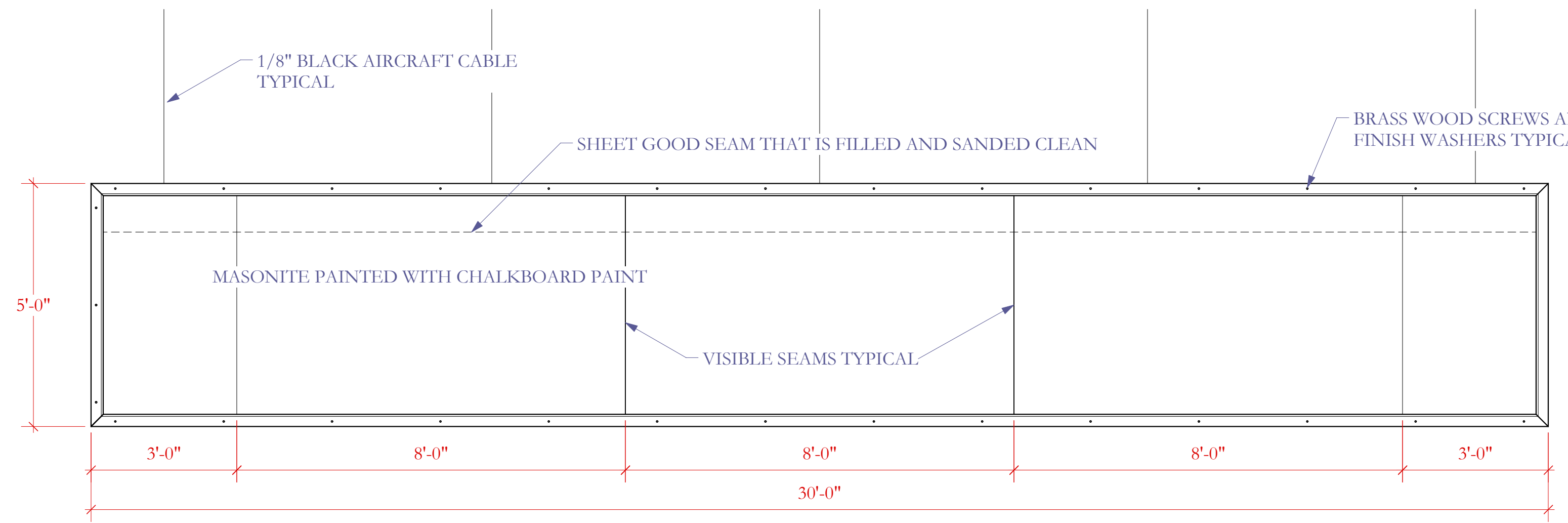

1 BOARD A: UPSTAGE FLYING BLACKBOARD
Scale: 1/2" = 1'-0"

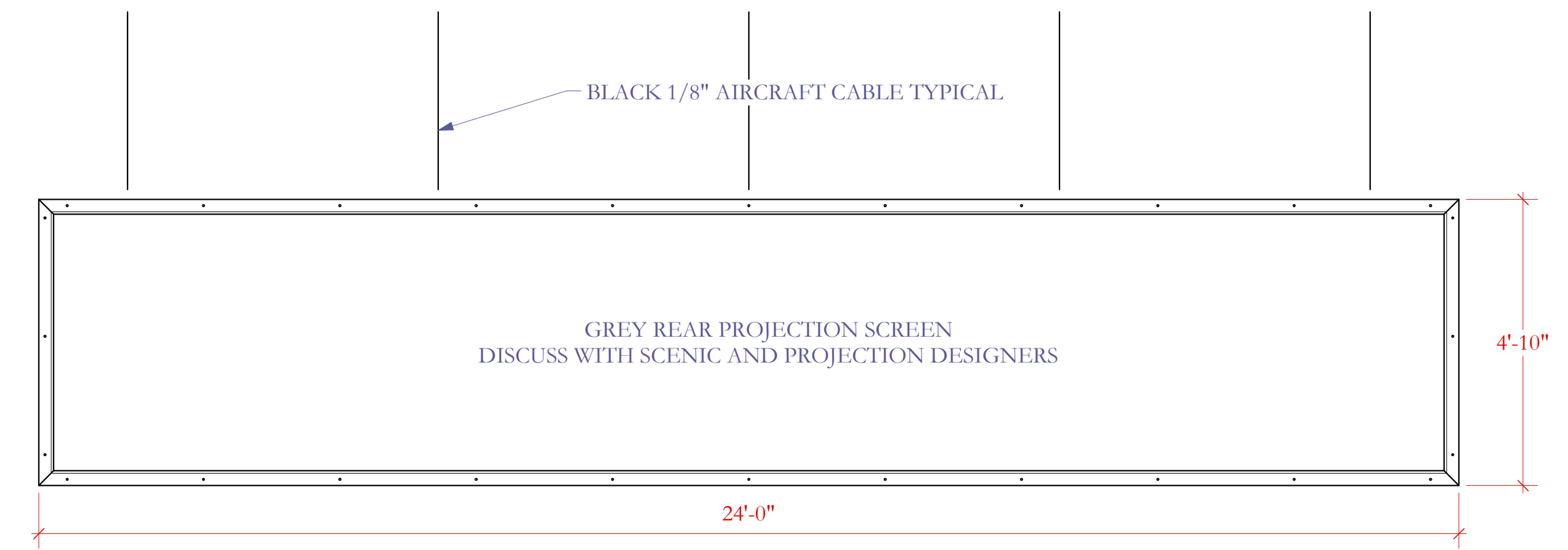

2 BOARD B: DEAD-HUNG MIDSTAGE PROJECTION BLACKBOARD
Scale: 1/2" = 1'-0"

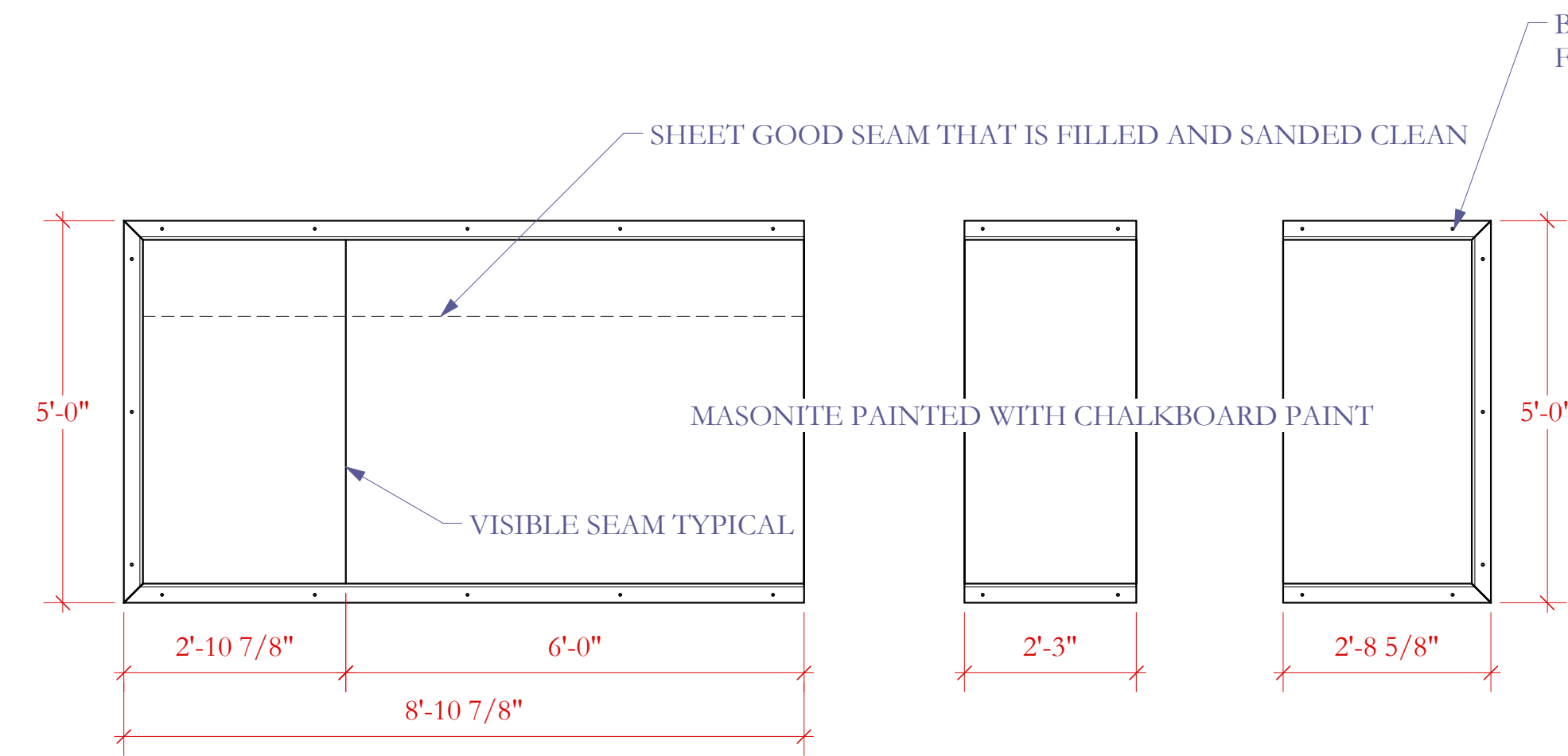

3 CHALKBOARD C
Scale: 1/2" = 1'-0"

4&5 CHALKBOARDS D AND E
Scale: 1/2" = 1'-0"

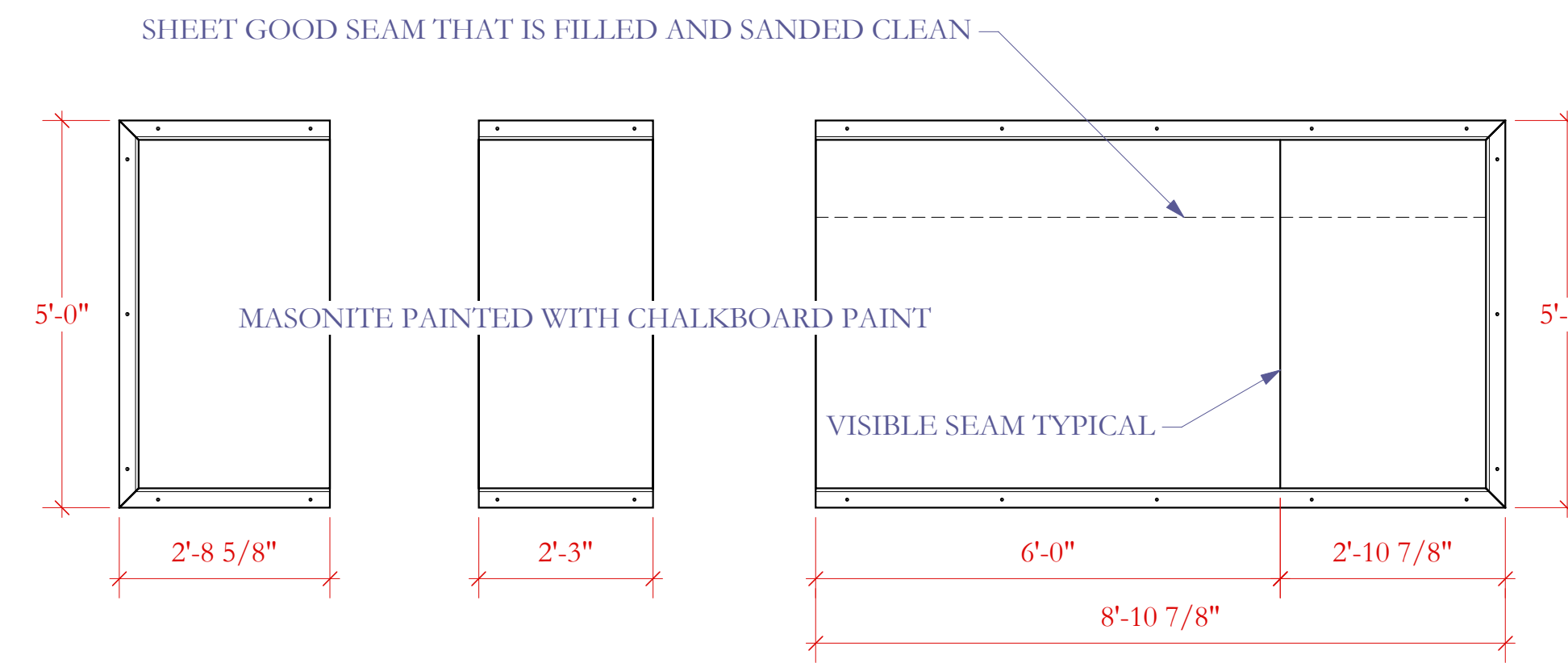

6&7 CHALKBOARDS F AND G
Scale: 1/2" = 1'-0"

8 CHALKBOARD H
Scale: 1/2" = 1'-0"

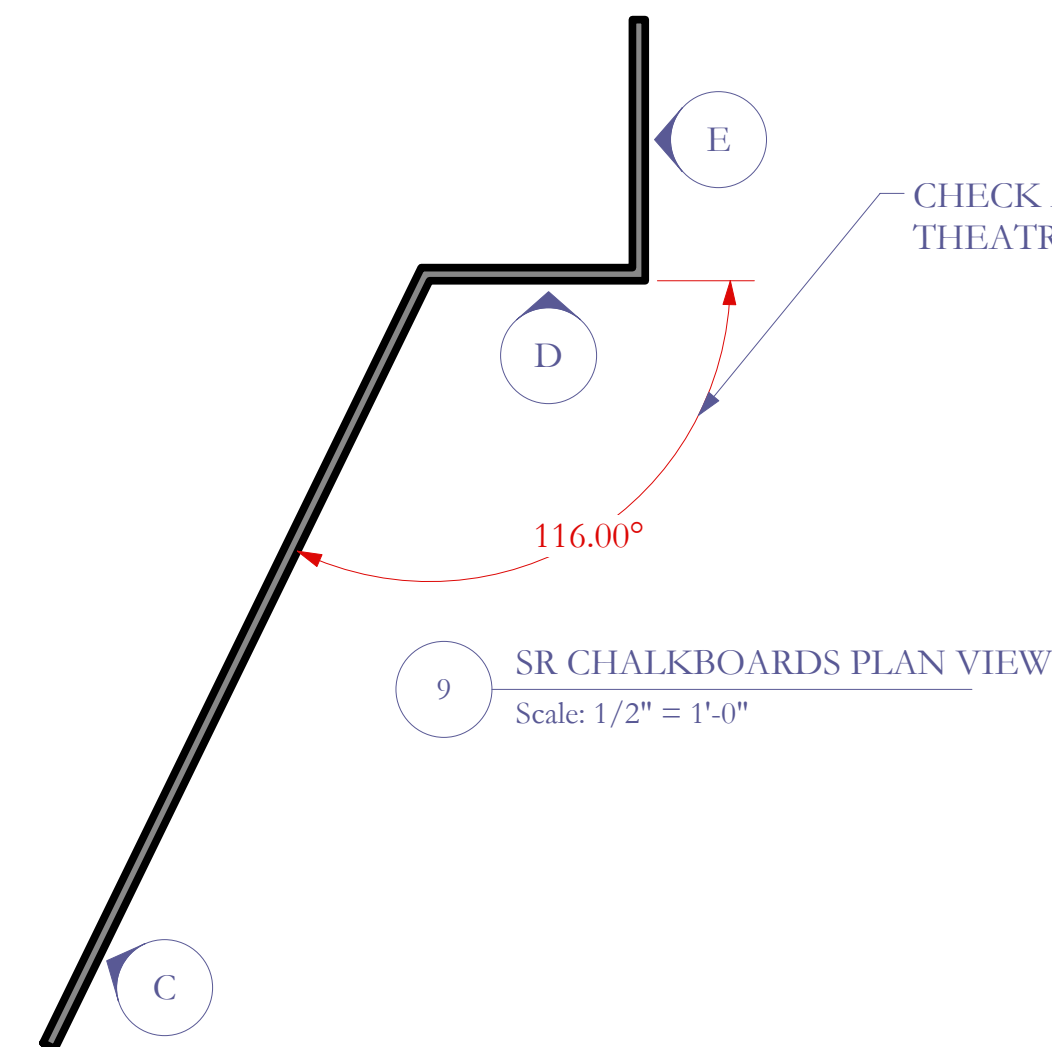

9 SR CHALKBOARDS PLAN VIEW
Scale: 1/2" = 1'-0"

CHECK ACTUAL MEASUREMENTS WITH THEATRE ARCHITECTURE

General Notes

- ALL CHALK BOARDS:
 - ARE FLATS COVERED WITH 1/8" MASONITE
 - HAVE HORIZONTAL SEAMS ARE FILLED AND SANDED SMOOTH
 - HAVE VISIBLE VERTICAL SEAMS
 - ARE FRAMED ON THE FACE WITH "OAK" 1X3
 - HAVE FACE FRAMES WHICH ARE ATTACHED WITH BRASS WOOD SCREWS AND FINISH WASHERS
 - ARE PAINTED WITH CHALKBOARD PAINT AND DUSTED WITH WHITE CHALK

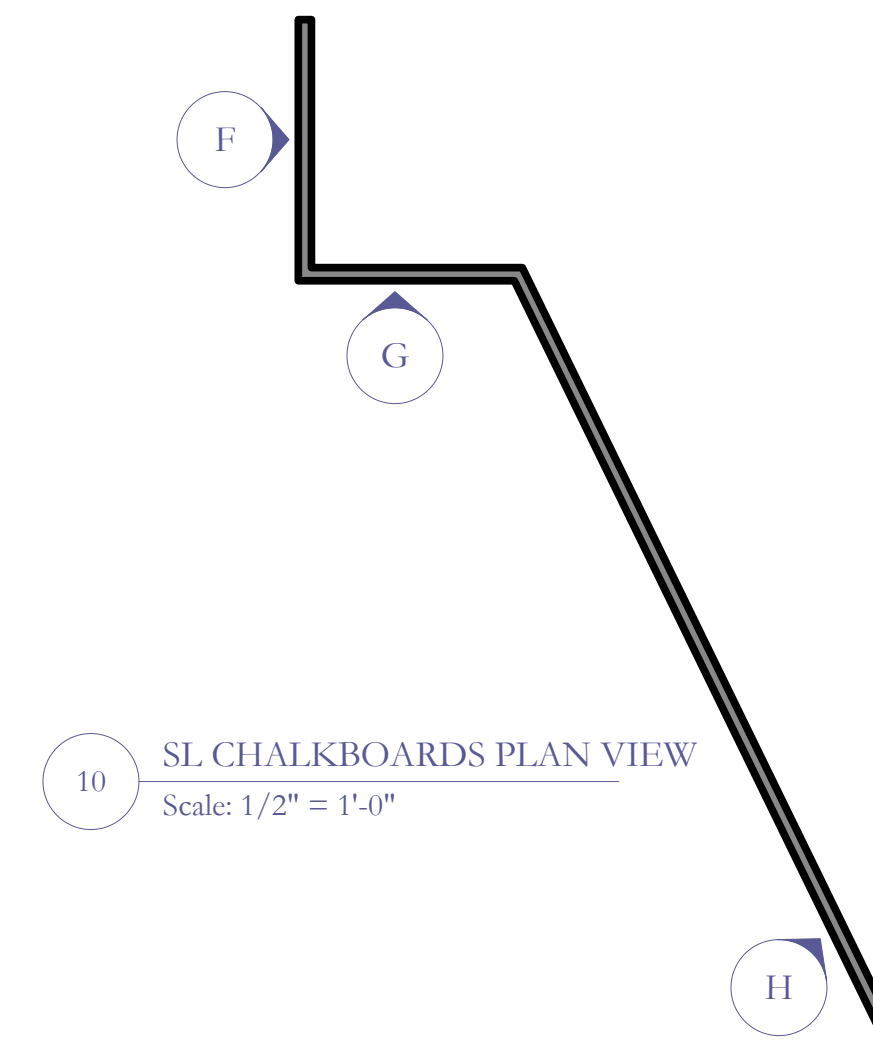

10 SL CHALKBOARDS PLAN VIEW
Scale: 1/2" = 1'-0"

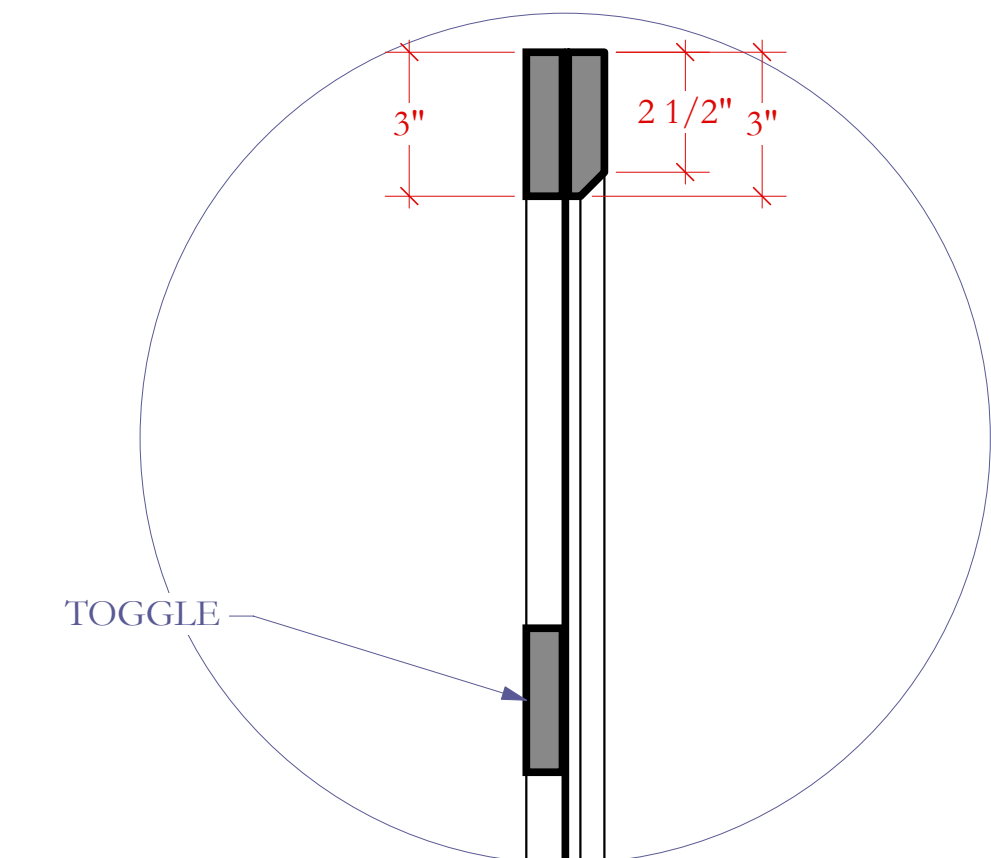

11 FRAME DETAIL
Scale: 3" = 1'-0"

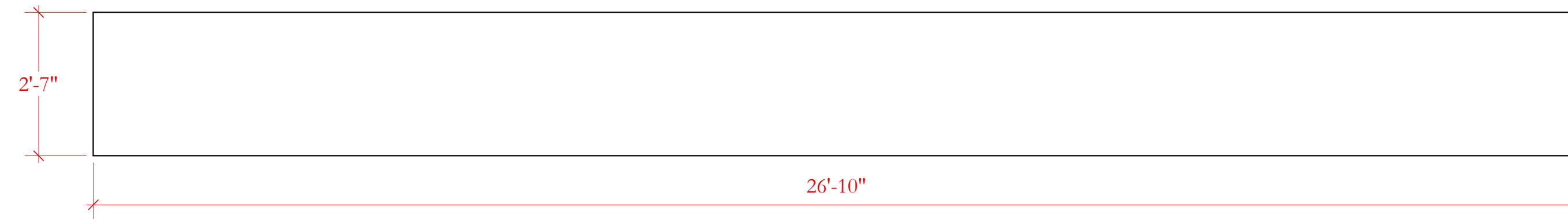

1 CEILING L: LIMESTONE PROSCENIUM BOTTOM VIEW
Scale: 1/2" = 1'-0"

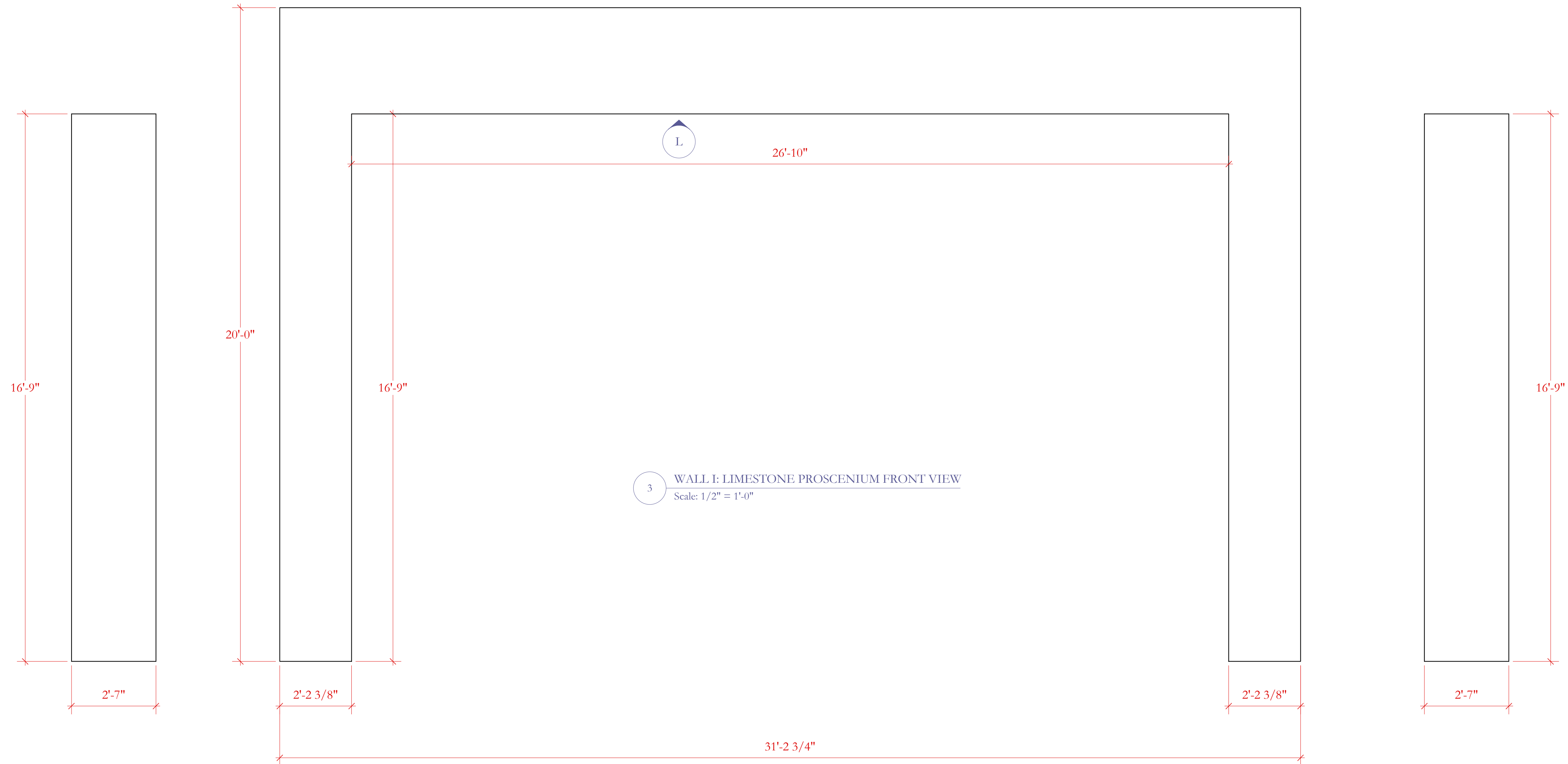

3 WALL I: LIMESTONE PROSCENIUM FRONT VIEW
Scale: 1/2" = 1'-0"

2 WALL J: LIMESTONE PROSCENIUM
Scale: 1/2" = 1'-0"

4 WALL K: LIMESTONE PROSCENIUM
Scale: 1/2" = 1'-0"

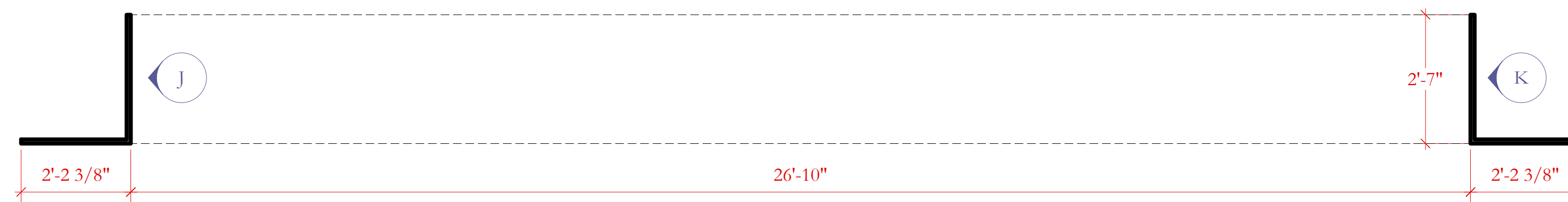

5 LIMESTONE PROSCENIUM PLAN VIEW
Scale: 1/2" = 1'-0"

THE HISTORY BOYS
PITTSBURGH IRISH AND CLASSICAL THEATRE ARTISTIC DIRECTOR: ANDREW PAUL
DIRECTED BY ANDREW PAUL, PRODUCTION MANAGER: PHIL MADORE, TECHNICAL DIRECTOR: PAUL BISTRICAN
1 FALSE PROSCENIUM
SCALE: 1/2"=1'-0"

DESIGNER: GIANNI DOWNS 412-779-7498
GIANNIDOWNS@GMAIL.COM
WWW.GIANNIDESIGNS.NET

DRAFTED: JULY 2, 2009
REVISED ON: JULY 7, 2009

PLATE:

5

OF 7

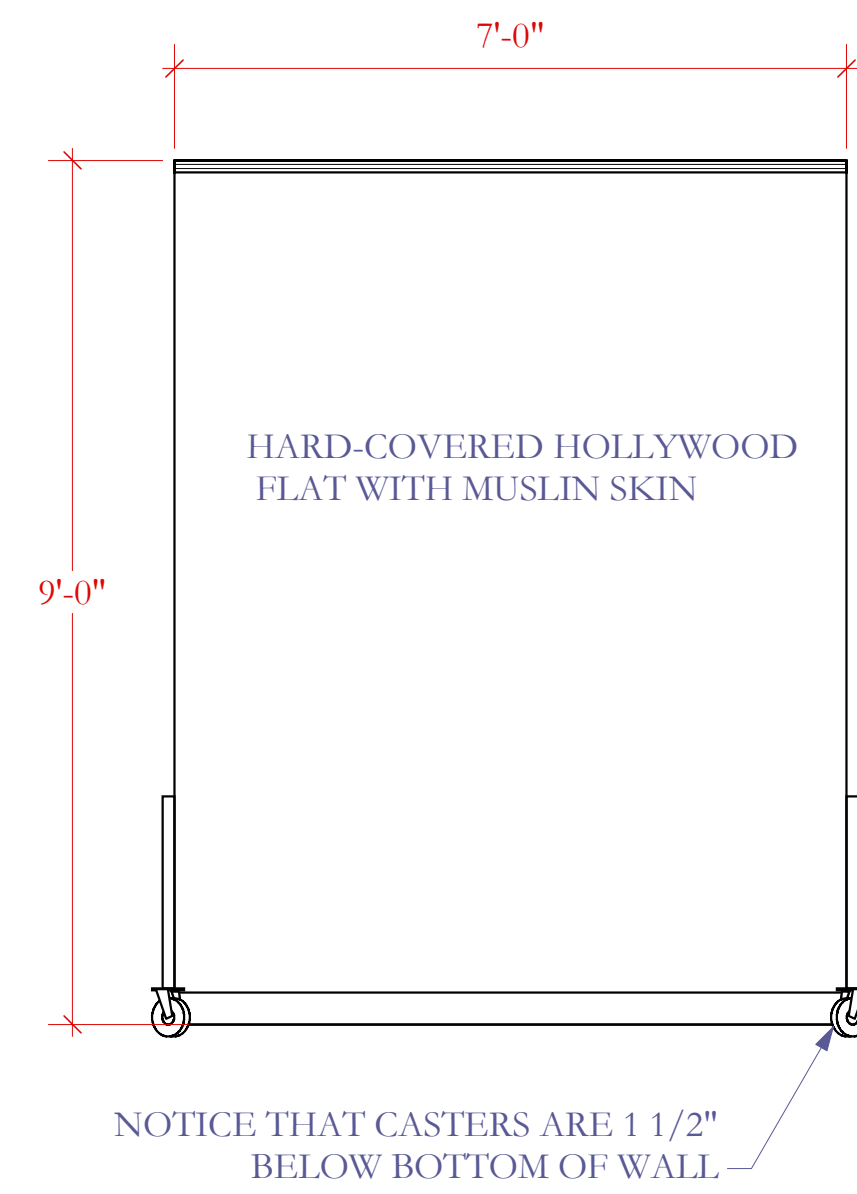
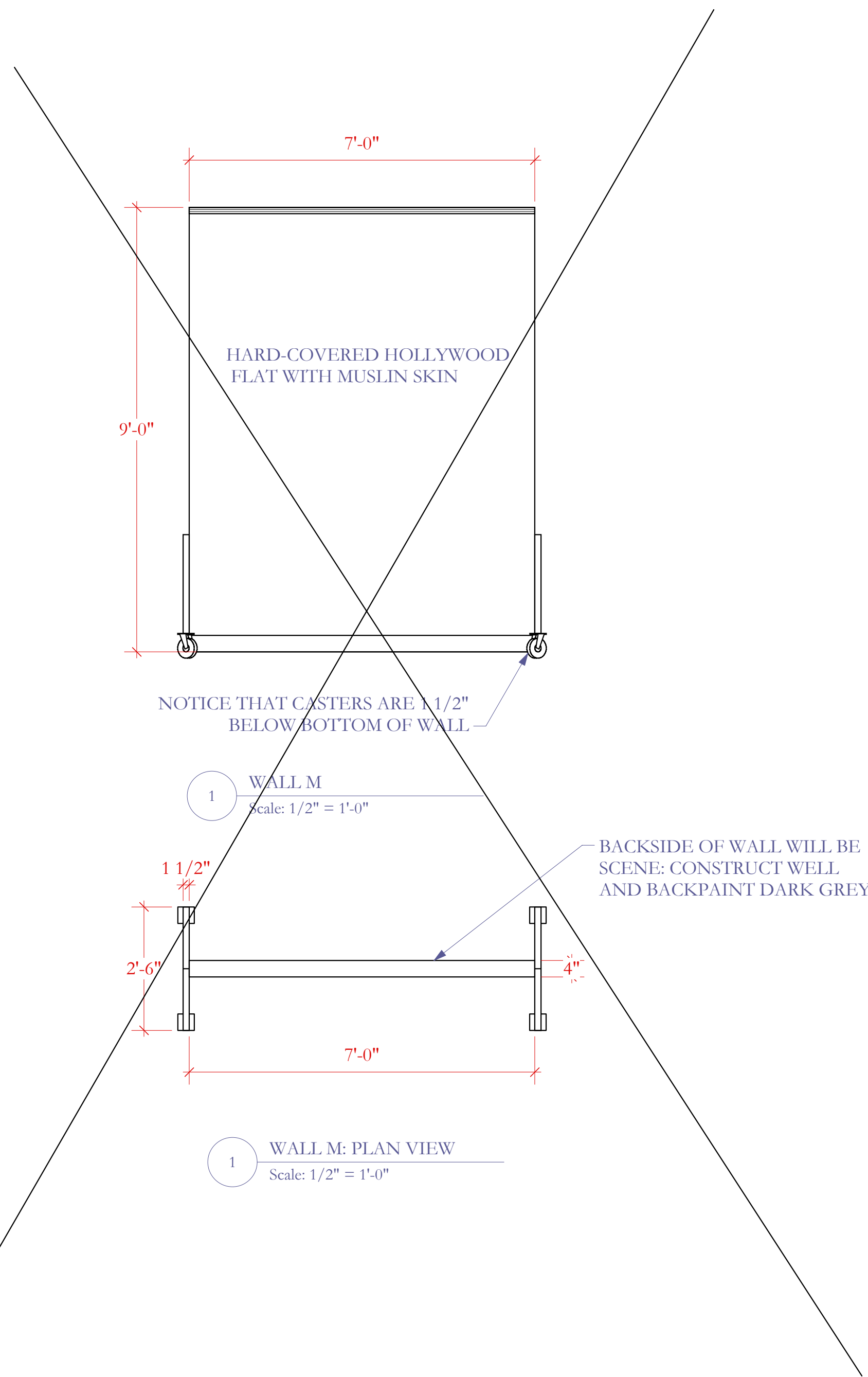

1 WALL N
Scale: 1/2" = 1'-0"

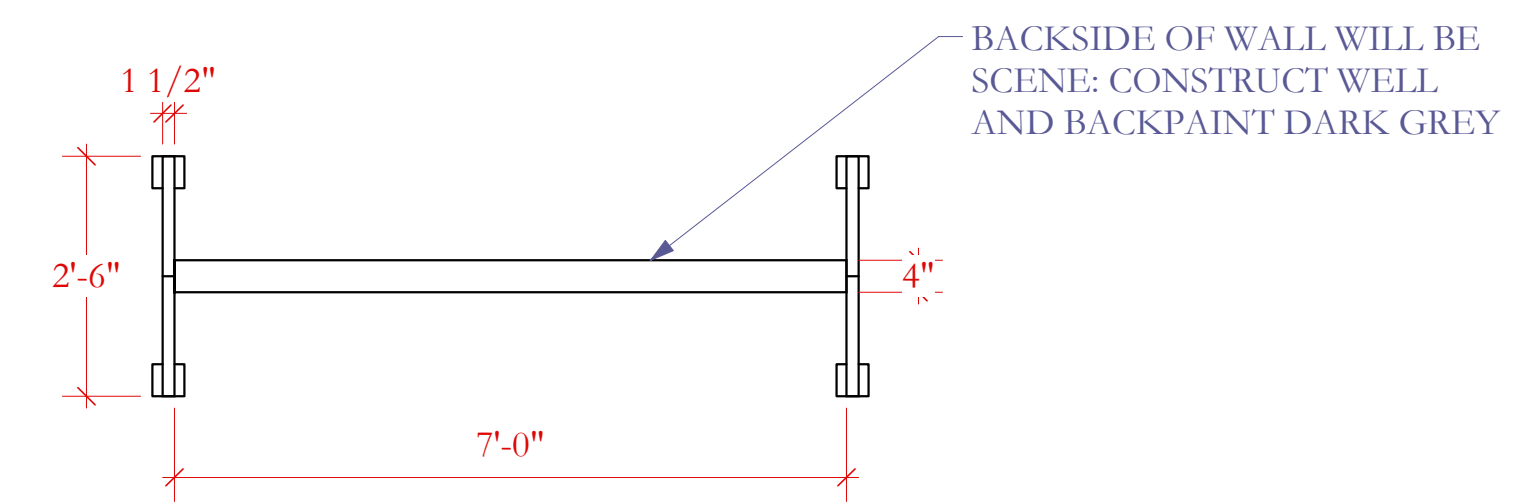

1 WALL N: PLAN VIEW
Scale: 1/2" = 1'-0"

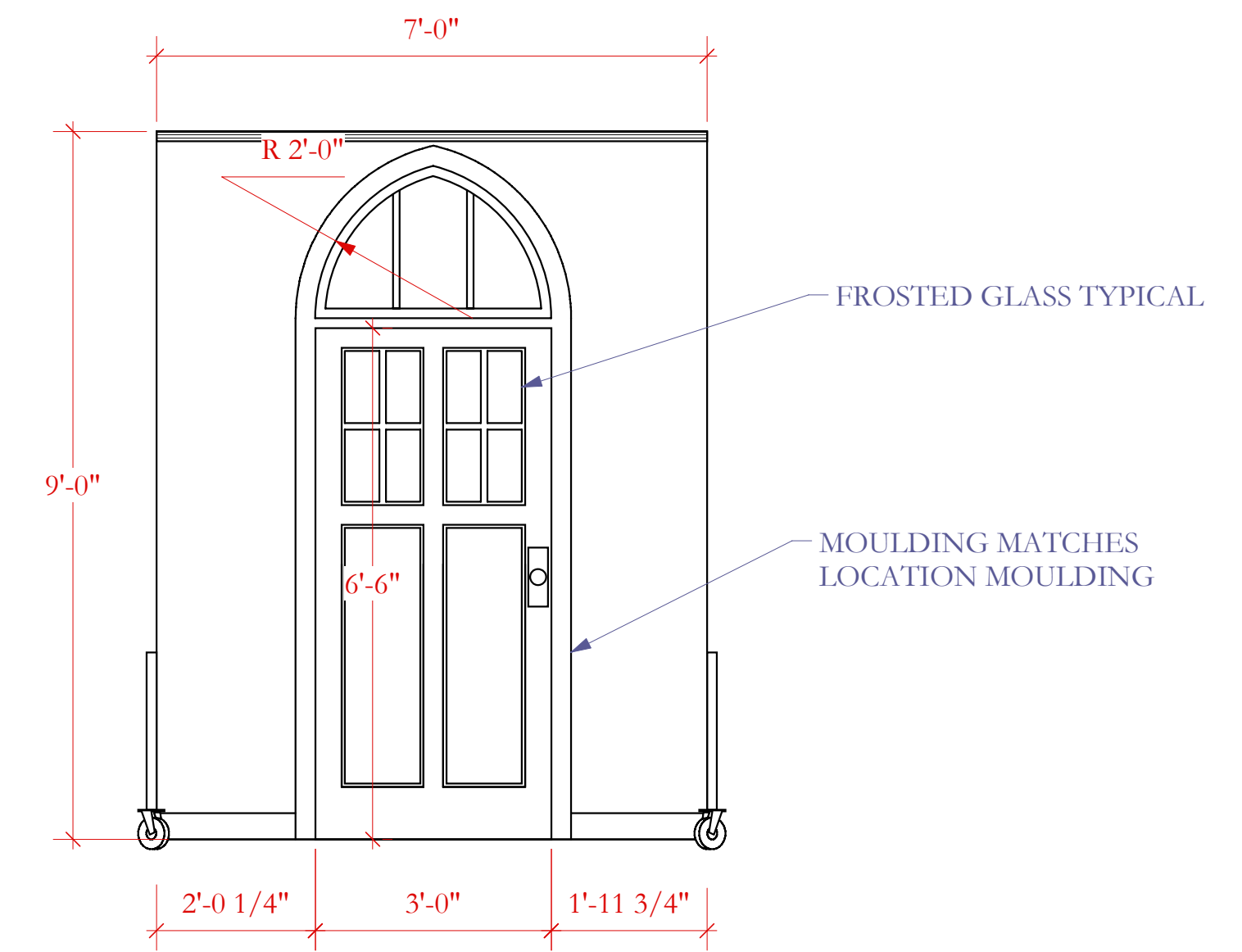

1 WALL O
Scale: 1/2" = 1'-0"

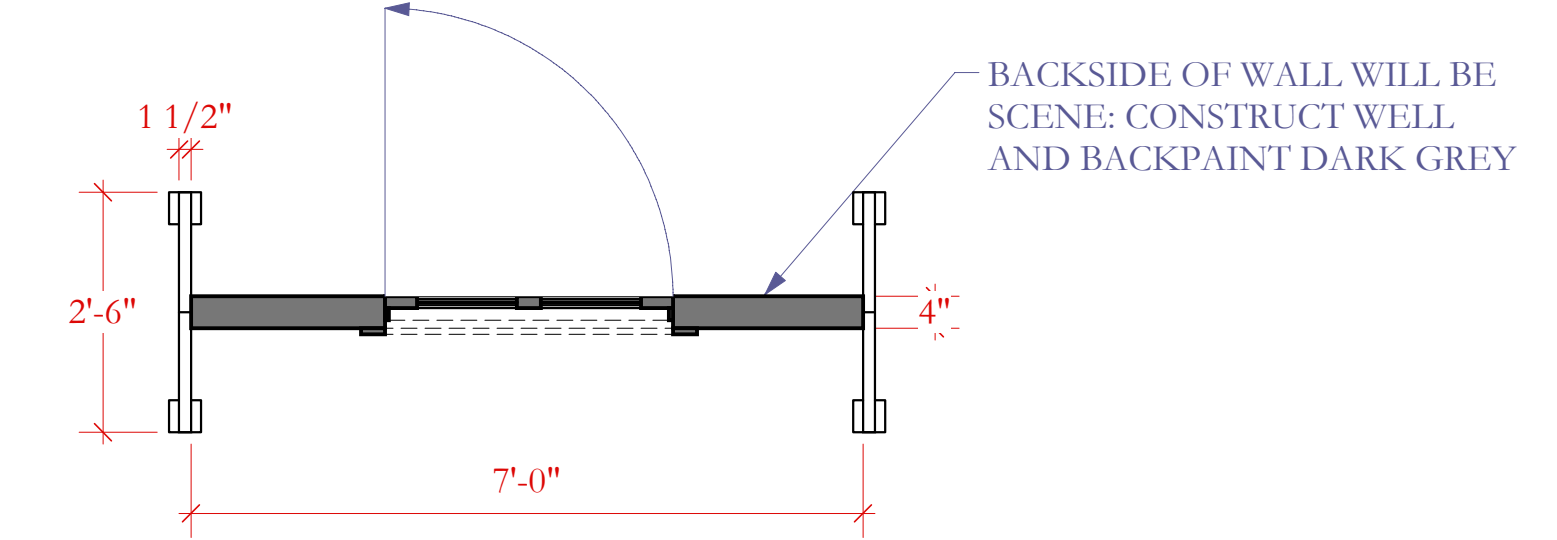

1 WALL O: PLAN VIEW
Scale: 1/2" = 1'-0"

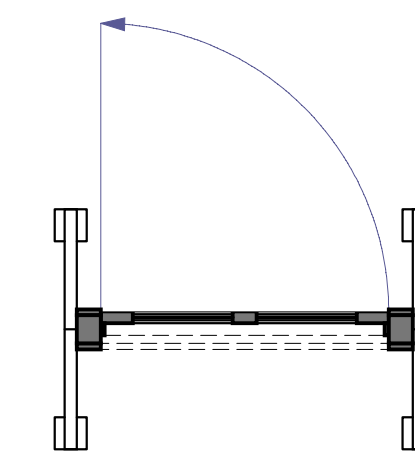
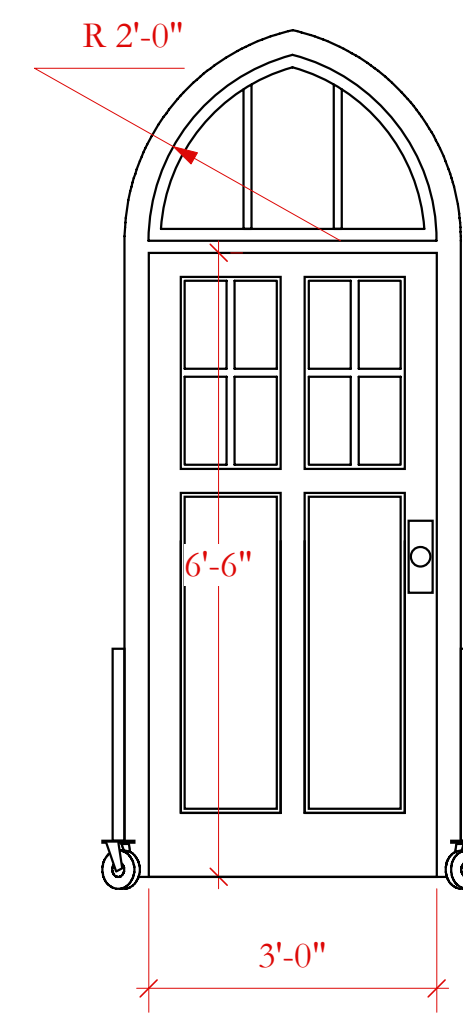

THE HISTORY BOYS

PITTSBURGH IRISH AND CLASSICAL THEATRE ARTISTIC DIRECTOR: ANDREW PAUL
DIRECTED BY: ANDREW PAUL, PRODUCTION MANAGER: PHIL MADORE, TECHNICAL DIRECTOR: PAUL BISTRICAN

ROLLING WALLS

SCALE 1/2" = 1'-0"

DESIGNER: GIANNI DOWNS 412-779-7498
GIANNIDOWNS@GMAIL.COM
WWW.GIANNIDESIGNS.NET

DRAFTED: JULY 2, 2009
REVISED ON: JULY 7, 2009

PLATE:

6

OF 7

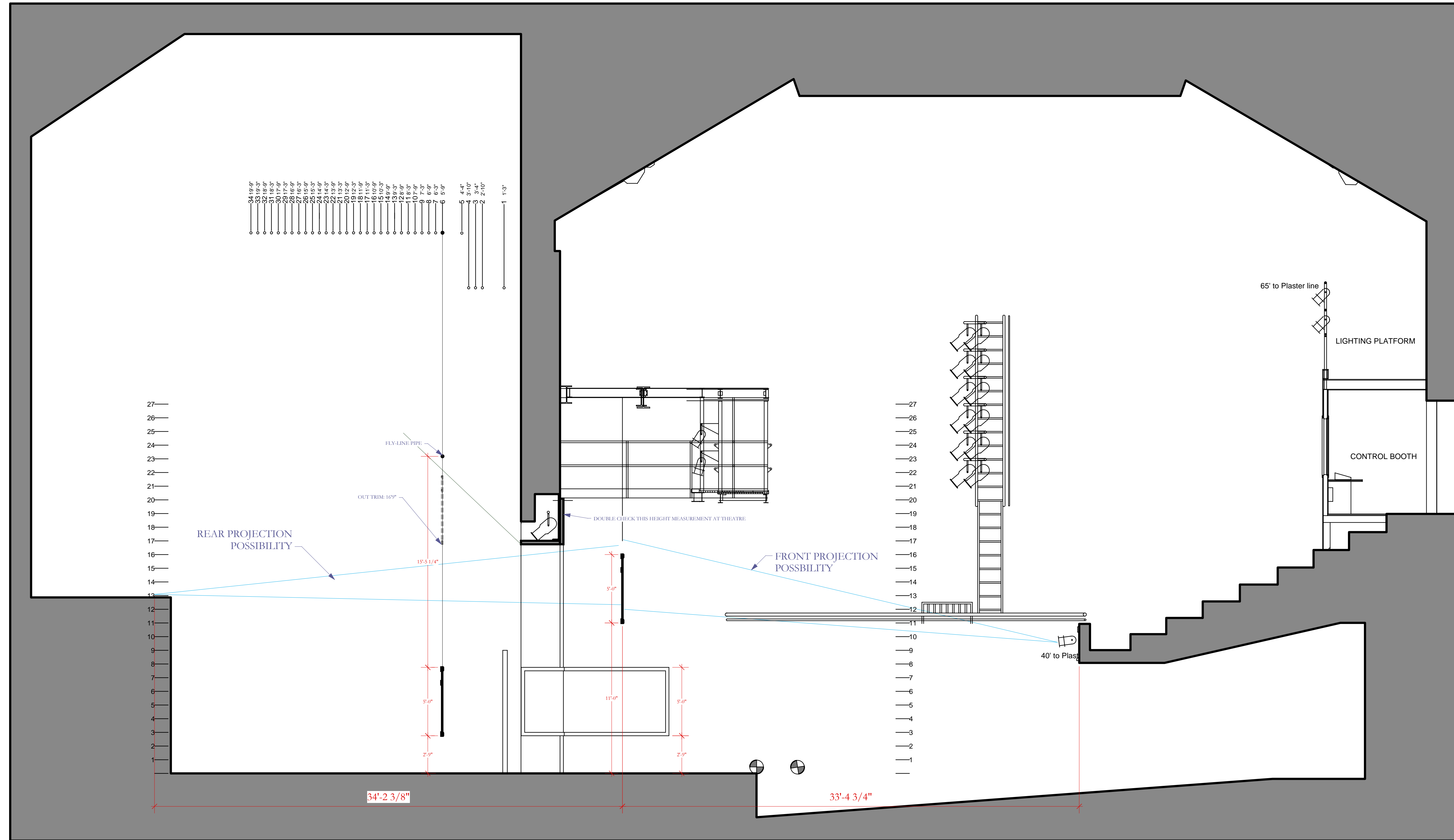

1 1/4" SECTION FOR PROJECTIONS
Scale: 1/4" = 1'-0"

THE HISTORY BOYS
PITTSBURGH IRISH AND CLASSICAL THEATRE, ARTISTIC DIRECTOR: ANDREW PAUL
DIRECTED BY ANDREW PAUL, PRODUCTION MANAGER: PHIL MADORE, TECHNICAL DIRECTOR: PAUL BISTRICAN

1/4" CENTERLINE SECTION

SCALE 1/4"=1'-0"

DESIGNER: GIANNI DOWNS 412-779-7498
GIANNIDOWNS@GMAIL.COM
WWW.GIANNIDESIGNS.NET

DRAFTED: JULY 2, 2009
REVISED ON: JULY 7, 2009

PLATE:

7

OF 7