

19'-9" 34
 19'-3" 33
 18'-9" 32
 18'-3" 31
 17'-9" 30
 17'-3" 29
 16'-9" 28
 16'-3" 27
 15'-9" 26
 15'-3" 25
 14'-9" 24
 14'-3" 23
 13'-9" 22
 13'-3" 21
 12'-9" 20
 12'-3" 19
 11'-9" 18
 11'-3" 17
 10'-9" 16
 10'-3" 15
 9'-9" 14
 9'-3" 13
 8'-9" 12
 8'-3" 11
 7'-9" 10
 7'-3" 9
 6'-9" 8
 6'-3" 7
 5'-9" 6

4'-4" 5
 3'-10" 4
 3'-4" 3
 2'-10" 2

1'-3" 1

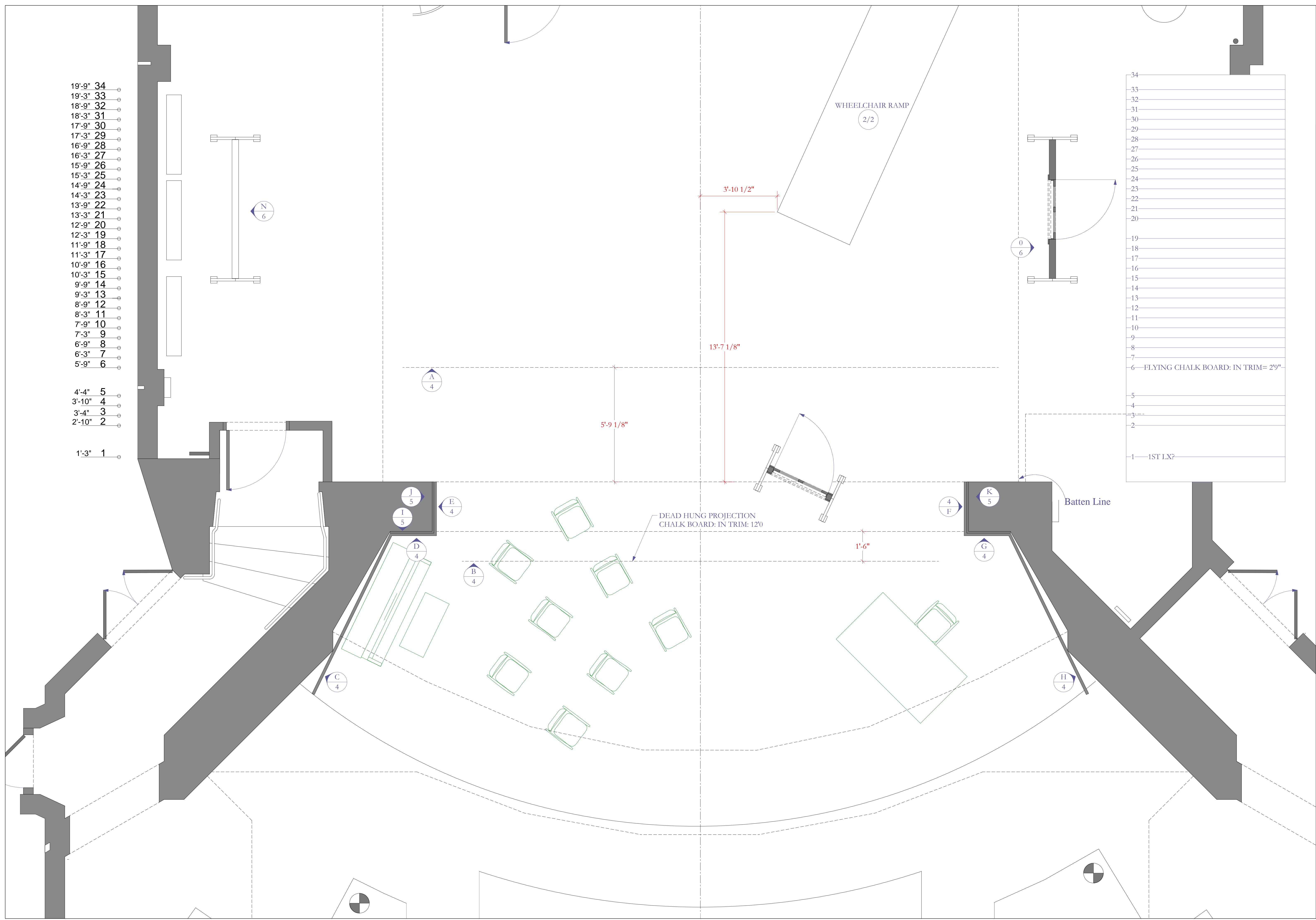

34
33
32
31
30
29
28
27
26
25
24
23
22
21
20
19
18
17
16
15
14
13
12
11
10
9
8
7
6
5
4
3
2
1

THE HISTORY BOYS
 PITTSBURGH IRISH AND CLASSICAL THEATRE, ARTISTIC DIRECTOR: ANDREW PAUL,
 DIRECTED BY ANDREW PAUL, PRODUCTION MANAGER: PHIL MADORE, TECHNICAL DIRECTOR: PAUL BISTRICAN

DESIGNER: GIANNI DOWNS 412-779-7498
 GIANNIDOWNS@GMAIL.COM
 WWW.GIANNIDESIGNS.NET

DRAFTED: JULY 2, 2009
 REVISED ON: JULY 7, 2009
 JULY 16, 2009

PLATE:
1
 OF 7

1/2" GROUND PLAN
 SCALE: 1/2"=1'-0"

19'-9" 34
 19'-3" 33
 18'-9" 32
 18'-3" 31
 17'-9" 30
 17'-3" 29
 16'-9" 28
 16'-3" 27
 15'-9" 26
 15'-3" 25
 14'-9" 24
 14'-3" 23
 13'-9" 22
 13'-3" 21
 12'-9" 20
 12'-3" 19
 11'-9" 18
 11'-3" 17
 10'-9" 16
 10'-3" 15
 9'-9" 14
 9'-3" 13
 8'-9" 12

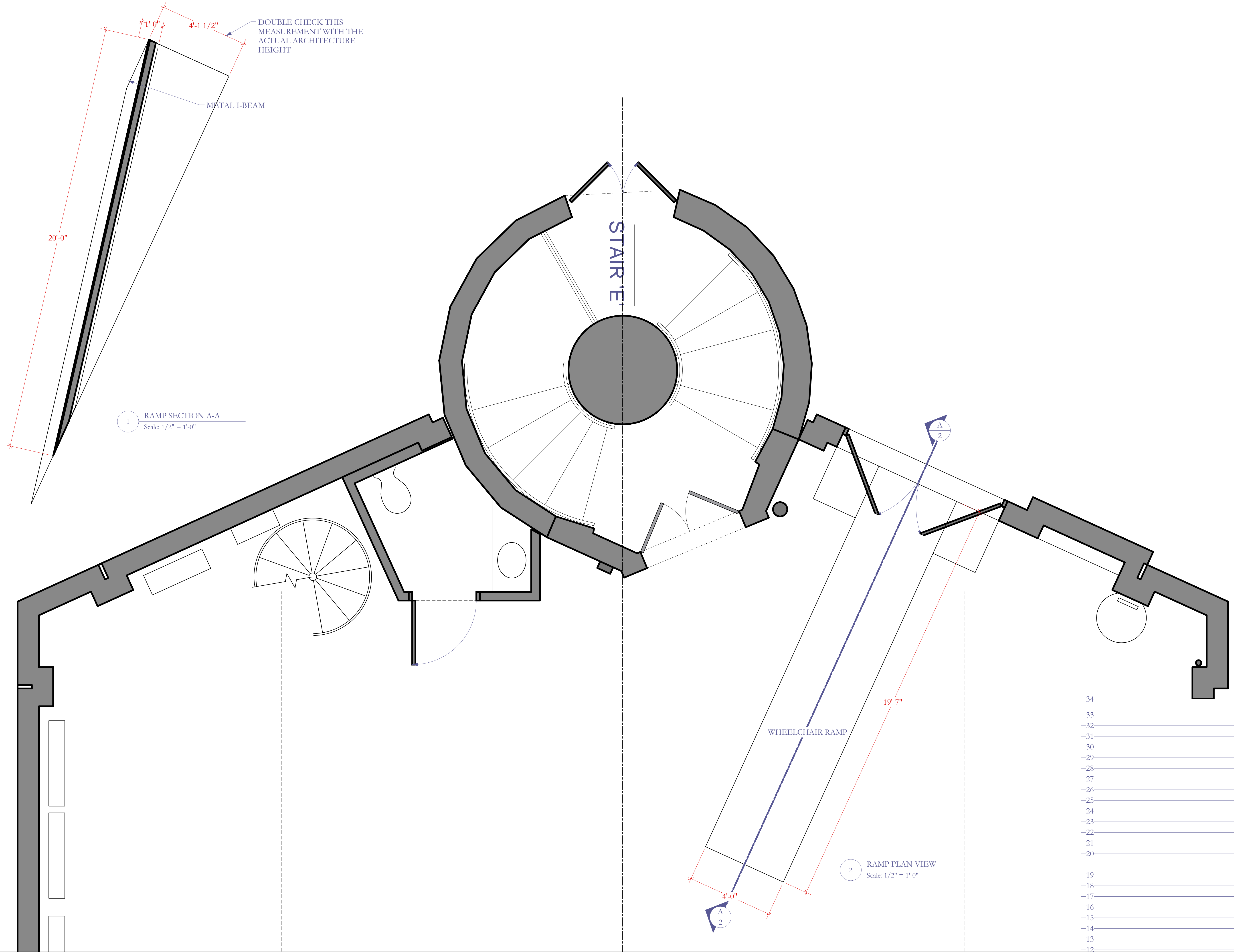

1 RAMP SECTION A-A
 Scale: 1/2" = 1'-0"

2 RAMP PLAN VIEW
 Scale: 1/2" = 1'-0"

34
33
32
31
30
29
28
27
26
25
24
23
22
21
20
19
18
17
16
15
14
13
12

<p>THE HISTORY BOYS PITTSBURGH IRISH AND CLASSICAL THEATRE ARTISTIC DIRECTOR: ANDREW PAUL DIRECTED BY: ANDREW PAUL, PRODUCTIONS MANAGER: PHIL MADORE, TECHNICAL DIRECTOR: PAUL BISTRICAN</p>	
<p>1/2" GROUND PLAN UPSTAGE AREAS SCALE: 1/2"=1'-0"</p>	
<p>DESIGNER: GIANNI DOWNS 412-779-7498 GIANNIDOWNS@GMAIL.COM WWW.GIANNIDESIGNS.NET</p>	<p>DRAFTED: JULY 2, 2009 REVISED ON: JULY 7, 2009</p>
<p>PLATE:</p>	<p>2</p>
<p>OF 7</p>	

27
26
25
24
23
22
21
20
19
18
17
16
15
14
13
12
11
10
9
8
7
6
5
4
3
2
1

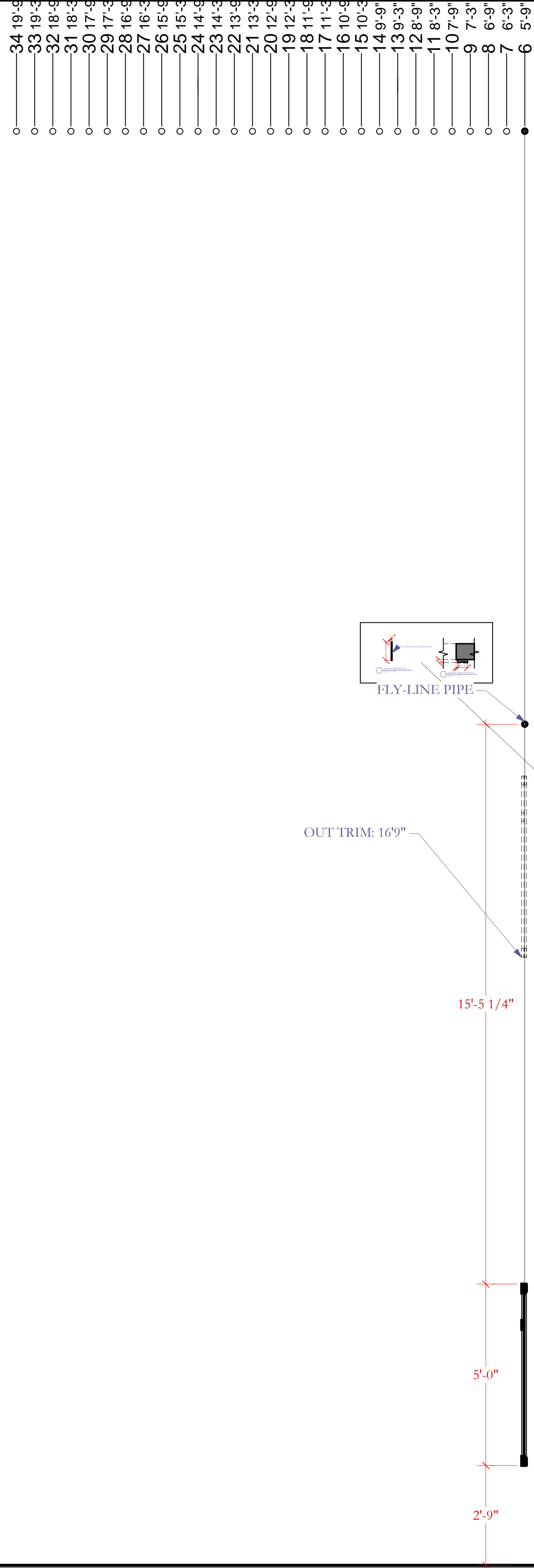

34 19'-6"
33 19'-3"
32 18'-6"
31 18'-3"
30 17'-9"
29 17'-3"
28 16'-9"
27 16'-3"
26 15'-9"
25 15'-3"
24 14'-9"
23 14'-3"
22 13'-9"
21 13'-3"
20 12'-9"
19 12'-3"
18 11'-9"
17 11'-3"
16 10'-9"
15 10'-3"
14 9'-9"
13 9'-3"
12 8'-9"
11 8'-3"
10 7'-9"
9 7'-3"
8 6'-9"
7 6'-3"
6 5'-9"
5 4'-4"
4 3'-10"
3 3'-4"
2 2'-10"
1 1'-3"

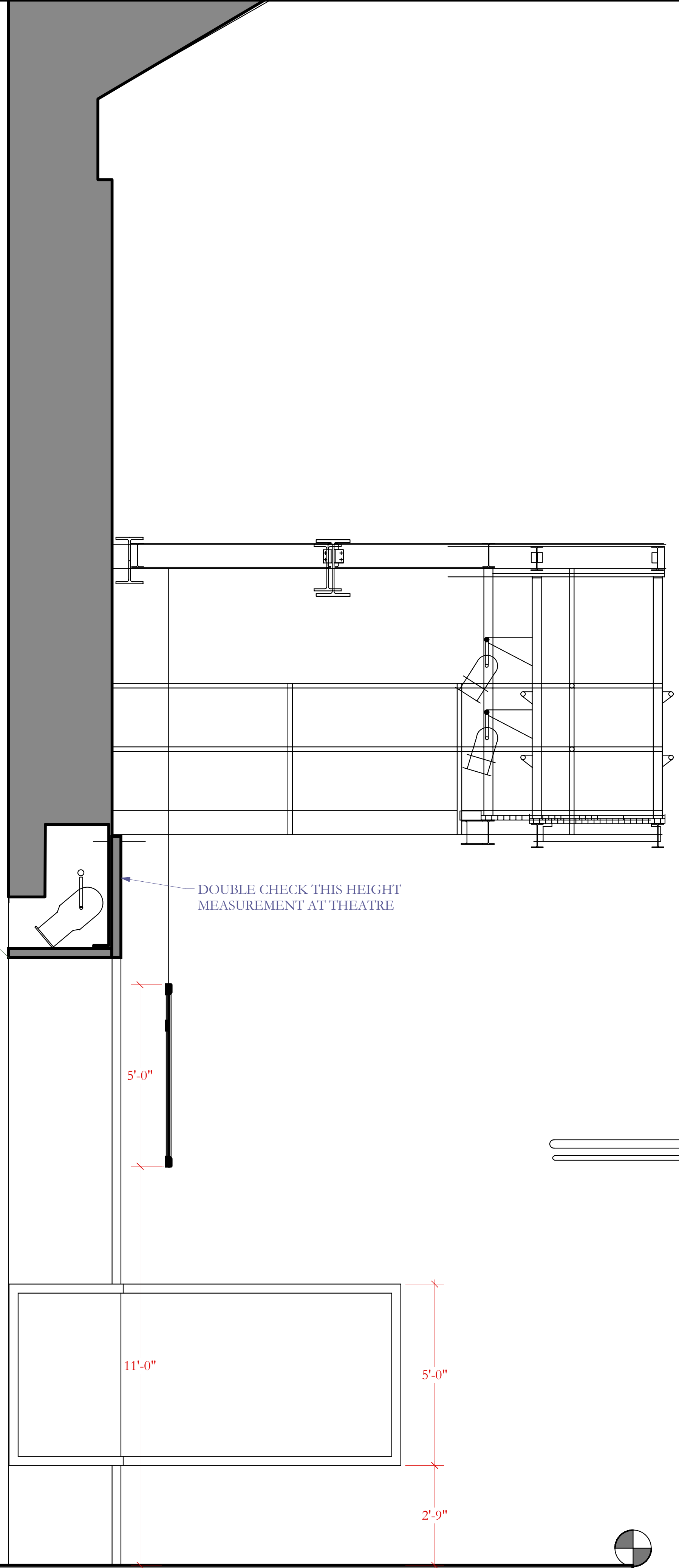

27
26
25
24
23
22
21
20
19
18
17
16
15
14
13
12
11
10
9
8
7
6
5
4
3
2
1

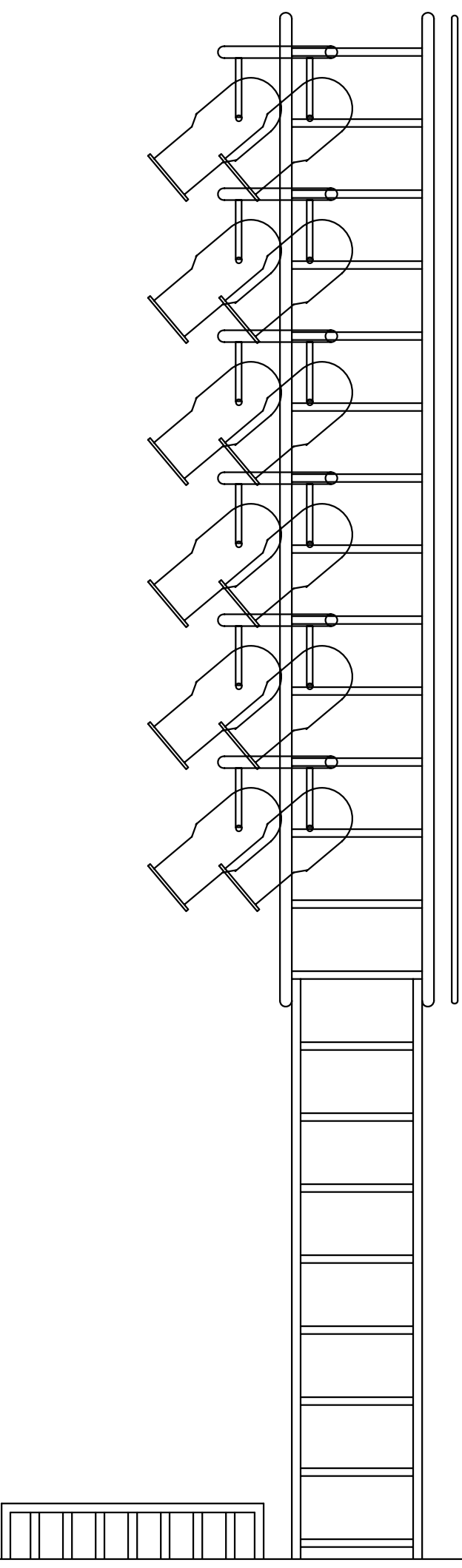

<p>THE HISTORY BOYS PITTSBURGH IRISH AND CLASSICAL THEATRE, ARTISTIC DIRECTOR: ANDREW PAUL, DIRECTED BY ANDREW PAUL, PRODUCTION MANAGER: PHIL MADORE, TECHNICAL DIRECTOR: PAUL BISTRICAN</p>	
<p>DESIGNER: GIANNI DOWNS 412-779-7498 GIANNIDOWNS@GMAIL.COM WWW.GIANNIDESIGNS.NET</p>	<p>DRAFTED: JULY 2, 2009 REVISED ON: JULY 7, 2009 JULY 16, 2009</p>
<p>PLATE:</p> <p>3</p>	<p>1/2" CENTERLINE SECTION SCALE 1/2"=1'-0"</p>
<p>OF 7</p>	

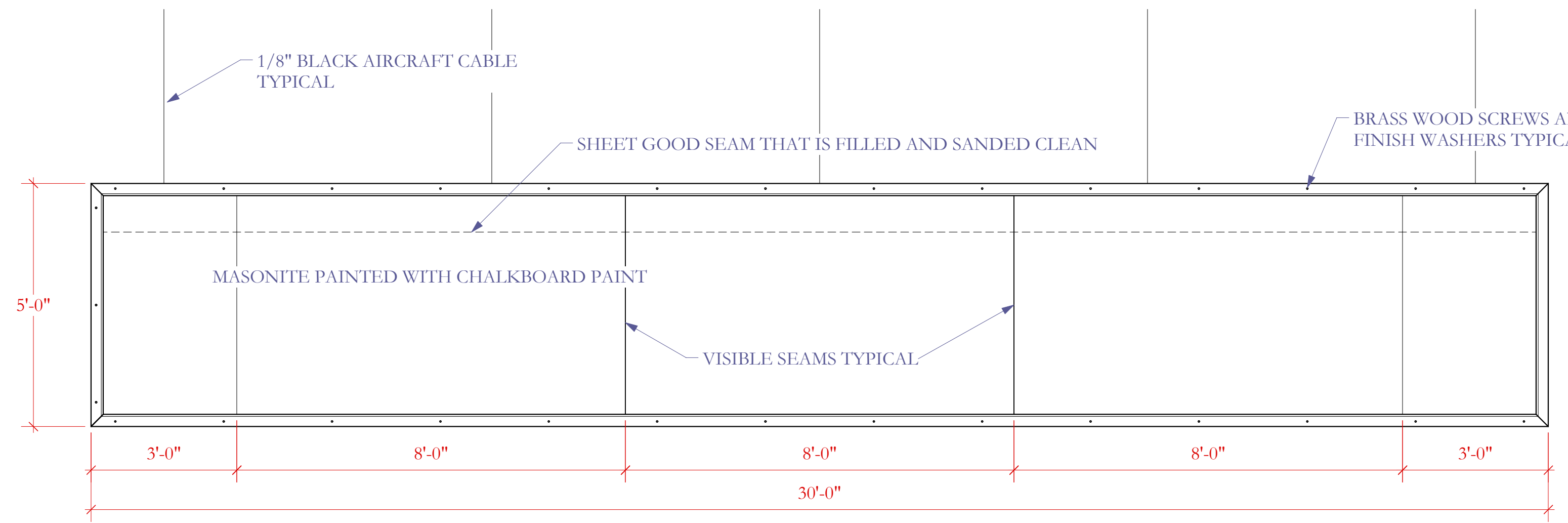

1 BOARD A: UPSTAGE FLYING BLACKBOARD
Scale: 1/2" = 1'-0"

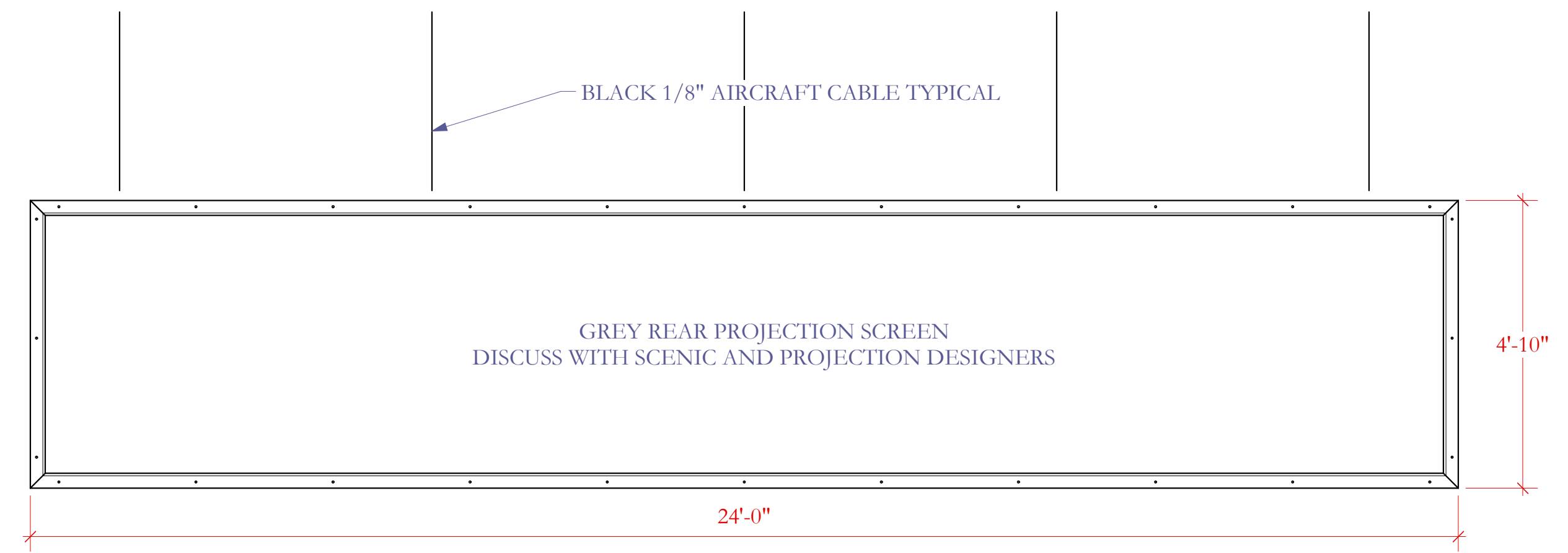

2 BOARD B: DEAD-HUNG MIDSTAGE PROJECTION BLACKBOARD
Scale: 1/2" = 1'-0"

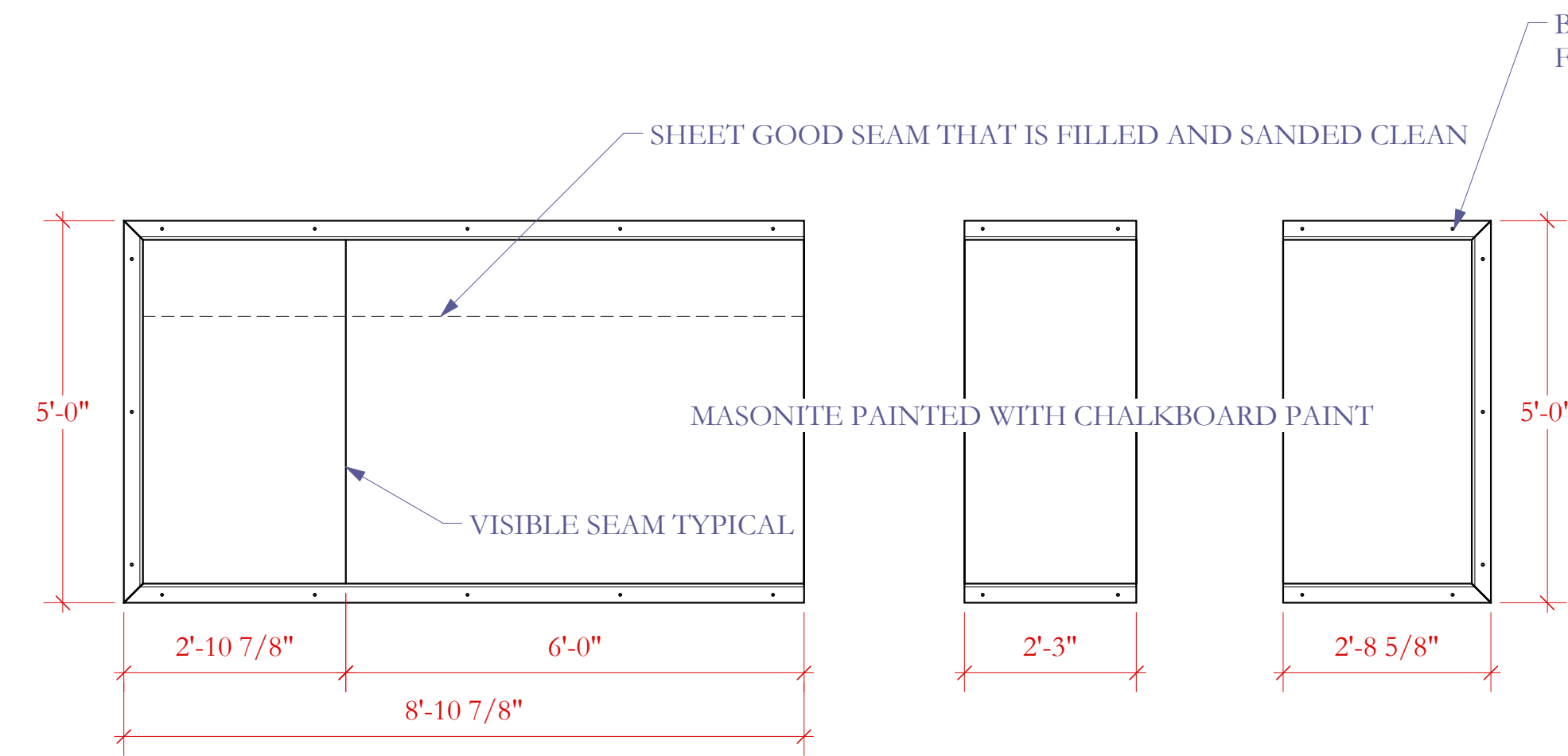

3 CHALKBOARD C
Scale: 1/2" = 1'-0"

4&5 CHALKBOARDS D AND E
Scale: 1/2" = 1'-0"

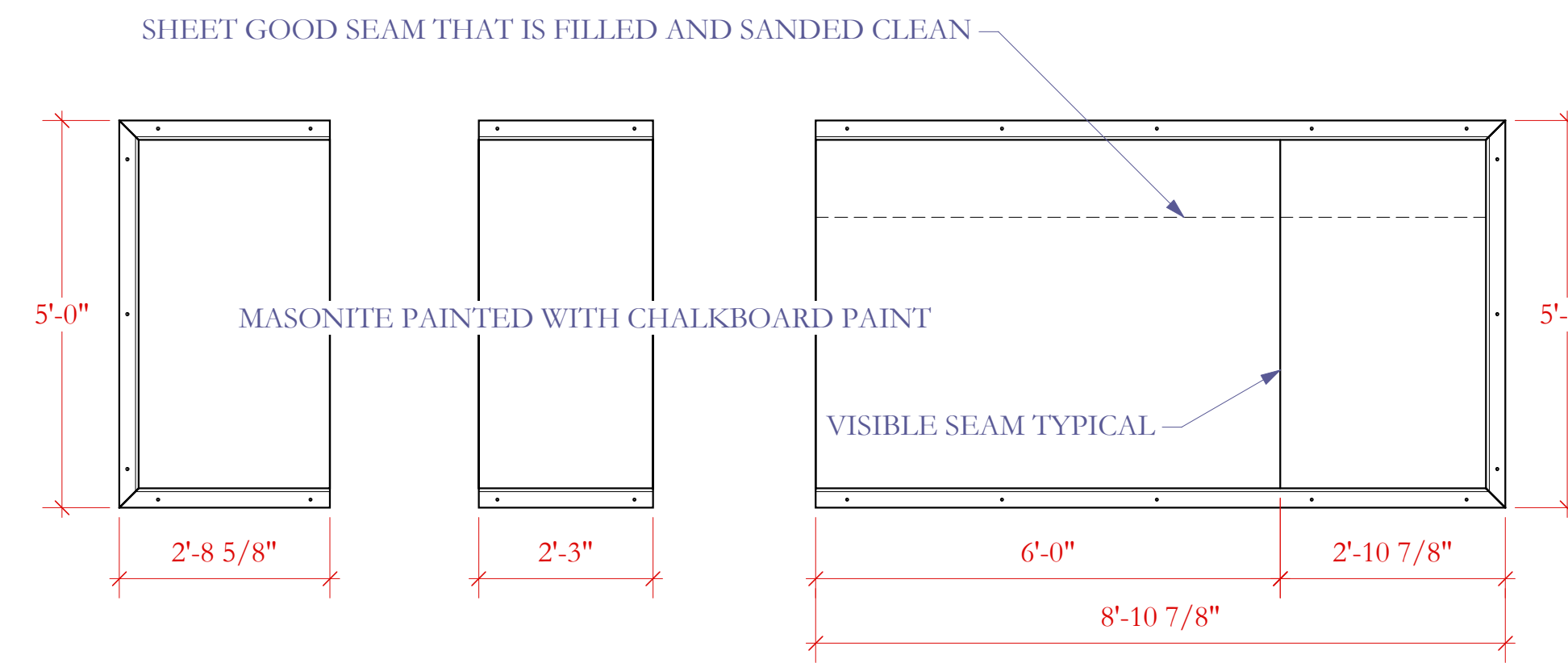

6&7 CHALKBOARDS F AND G
Scale: 1/2" = 1'-0"

8 CHALKBOARD H
Scale: 1/2" = 1'-0"

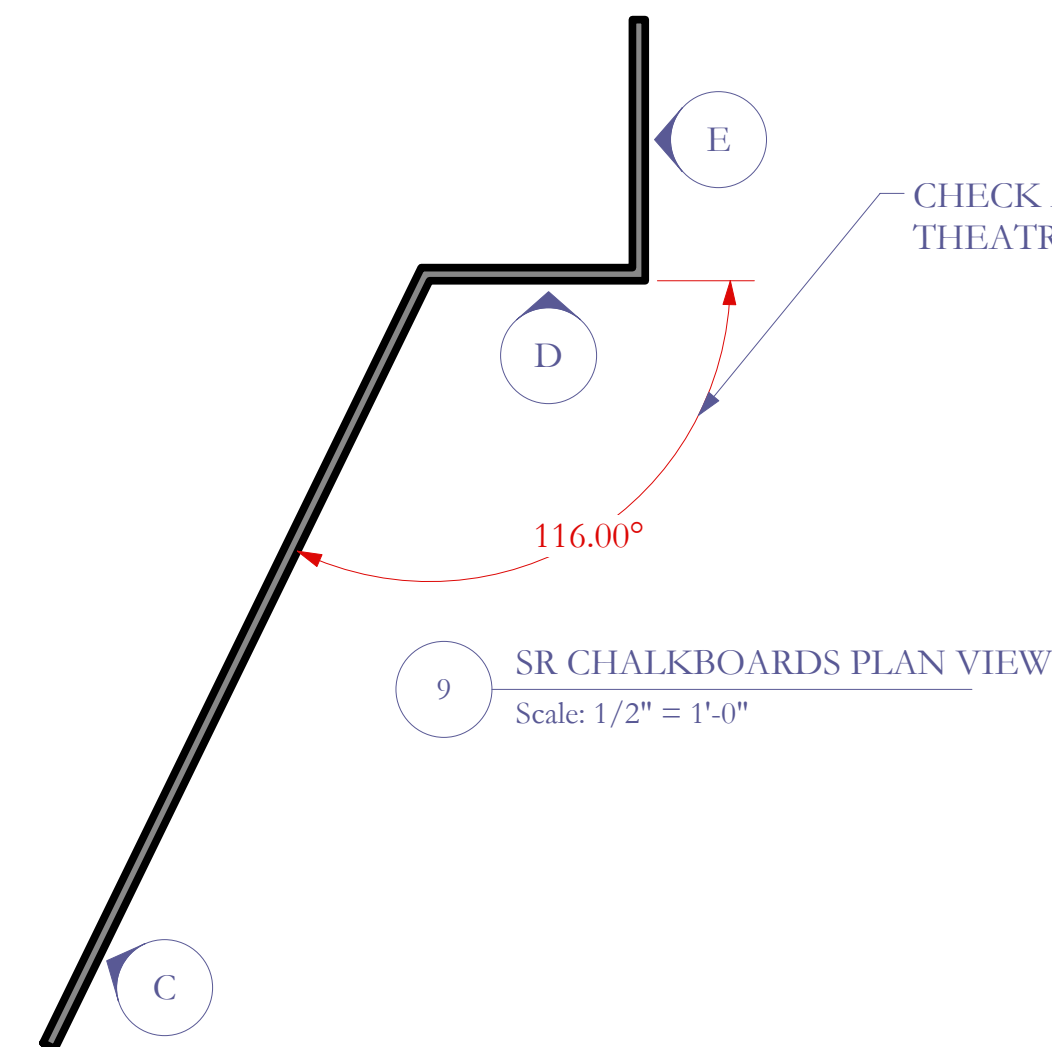

9 SR CHALKBOARDS PLAN VIEW
Scale: 1/2" = 1'-0"

General Notes

- ALL CHALK BOARDS:
 - ARE FLATS COVERED WITH 1/8" MASONITE
 - HAVE HORIZONTAL SEAMS ARE FILLED AND SANDED SMOOTH
 - HAVE VISIBLE VERTICAL SEAMS
 - ARE FRAMED ON THE FACE WITH "OAK" 1X3
 - HAVE FACE FRAMES WHICH ARE ATTACHED WITH BRASS WOOD SCREWS AND FINISH WASHERS
 - ARE PAINTED WITH CHALKBOARD PAINT AND DUSTED WITH WHITE CHALK

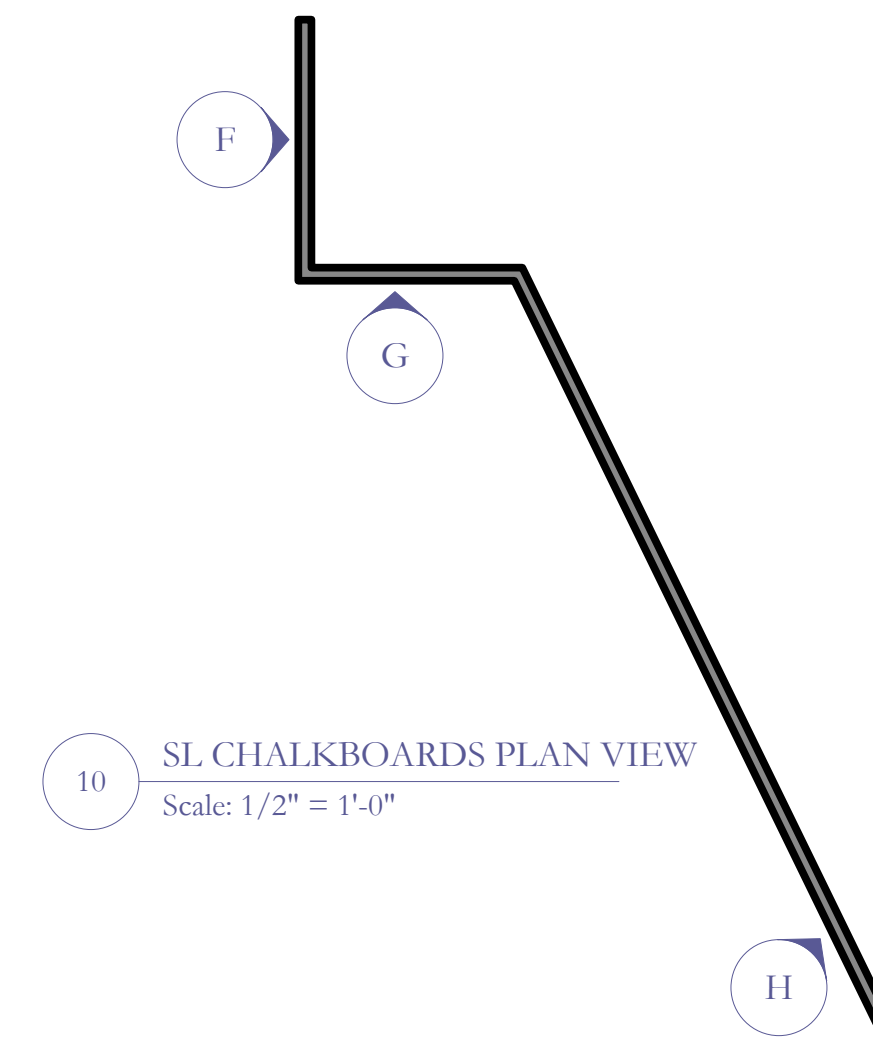

10 SL CHALKBOARDS PLAN VIEW
Scale: 1/2" = 1'-0"

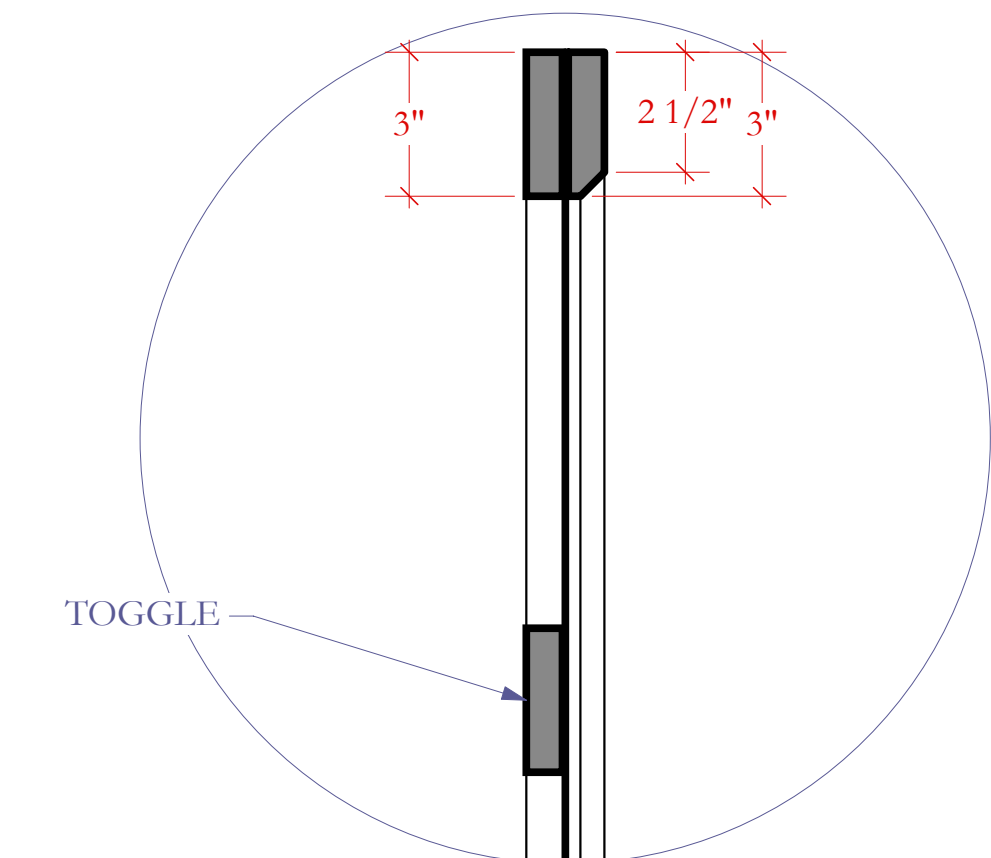

11 FRAME DETAIL
Scale: 3" = 1'-0"

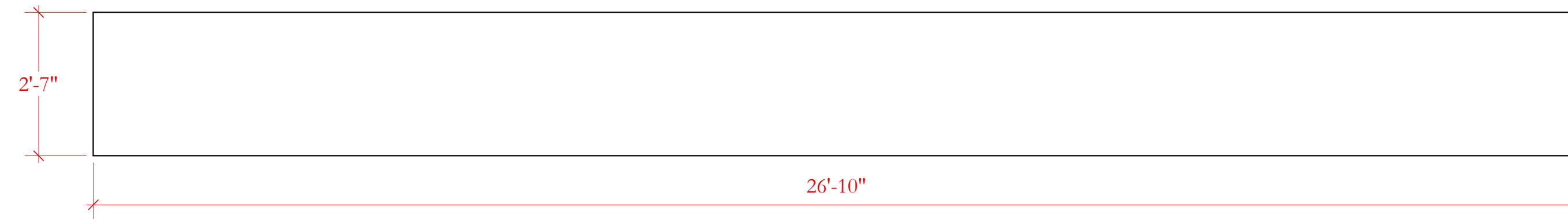

1 CEILING L: LIMESTONE PROSCENIUM BOTTOM VIEW
Scale: 1/2" = 1'-0"

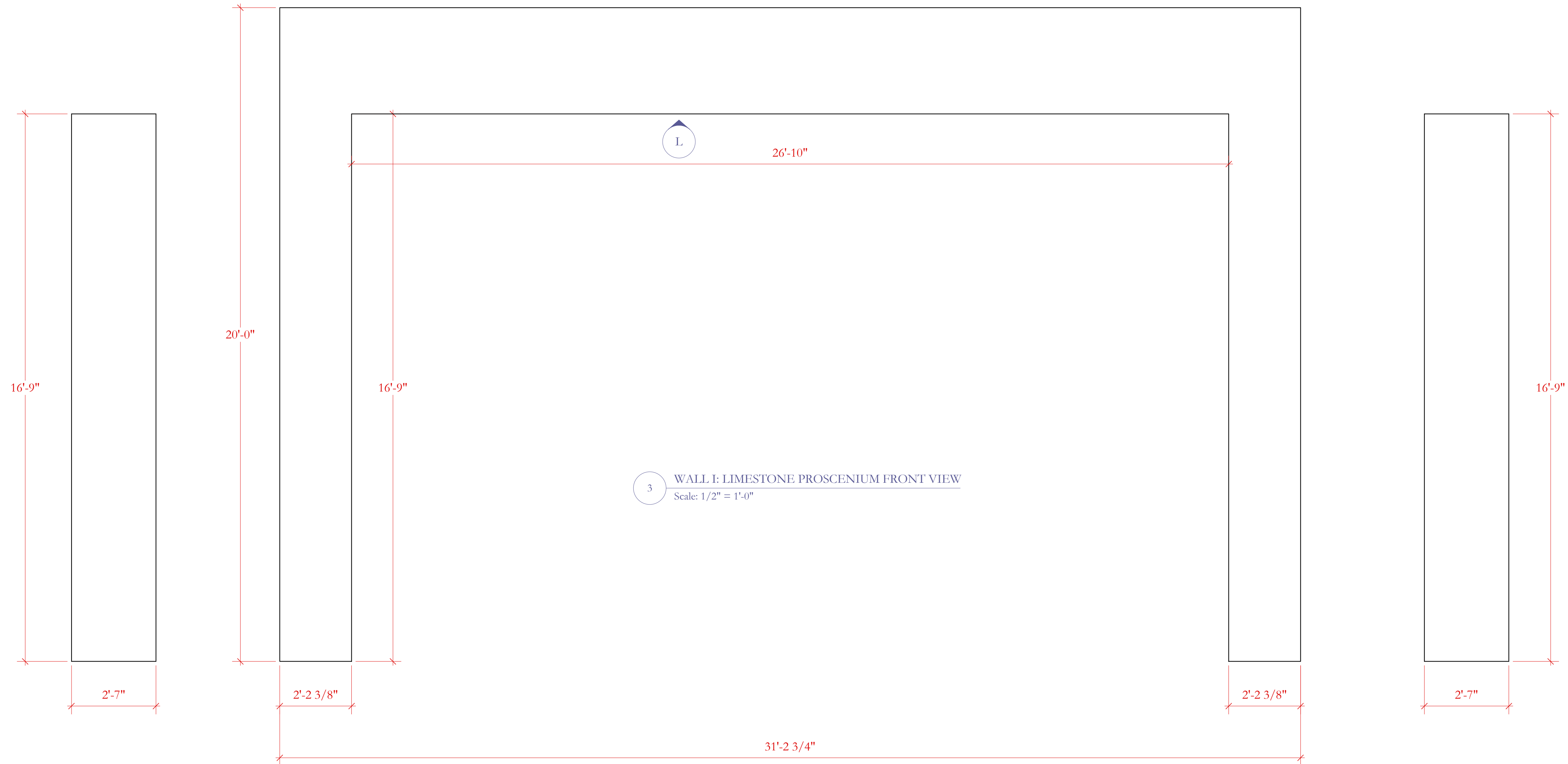

3 WALL I: LIMESTONE PROSCENIUM FRONT VIEW
Scale: 1/2" = 1'-0"

2 WALL J: LIMESTONE PROSCENIUM
Scale: 1/2" = 1'-0"

4 WALL K: LIMESTONE PROSCENIUM
Scale: 1/2" = 1'-0"

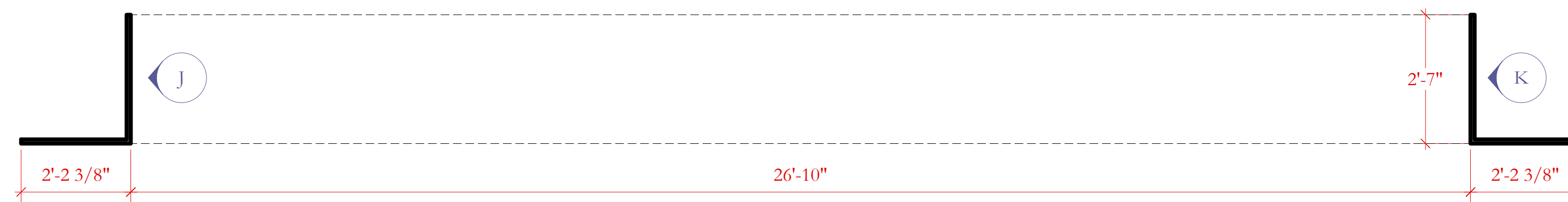

5 LIMESTONE PROSCENIUM PLAN VIEW
Scale: 1/2" = 1'-0"

THE HISTORY BOYS
PITTSBURGH IRISH AND CLASSICAL THEATRE ARTISTIC DIRECTOR: ANDREW PAUL
DIRECTED BY ANDREW PAUL, PRODUCTION MANAGER: PHIL MADORE, TECHNICAL DIRECTOR: PAUL BISTRICAN

1 FALSE PROSCENIUM
SCALE: 1/2"=1'-0"

DESIGNER: GIANNI DOWNS 412-779-7498
GIANNIDOWNS@GMAIL.COM
WWW.GIANNIDESIGNS.NET

DRAFTED: JULY 2, 2009
REVISED ON: JULY 7, 2009

PLATE:

5

OF 7

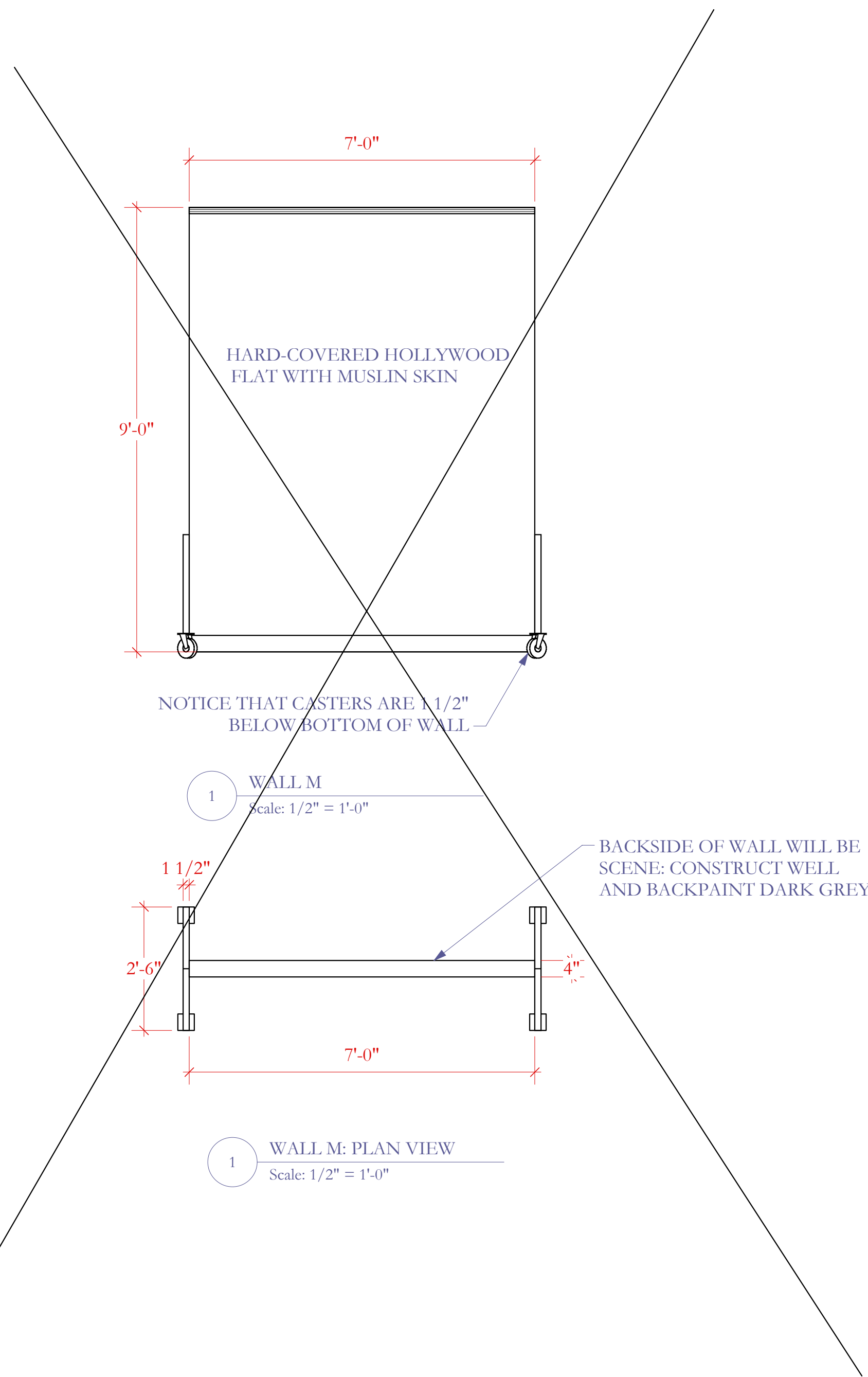

1 WALL M
Scale: 1/2" = 1'-0"

1 WALL M: PLAN VIEW
Scale: 1/2" = 1'-0"

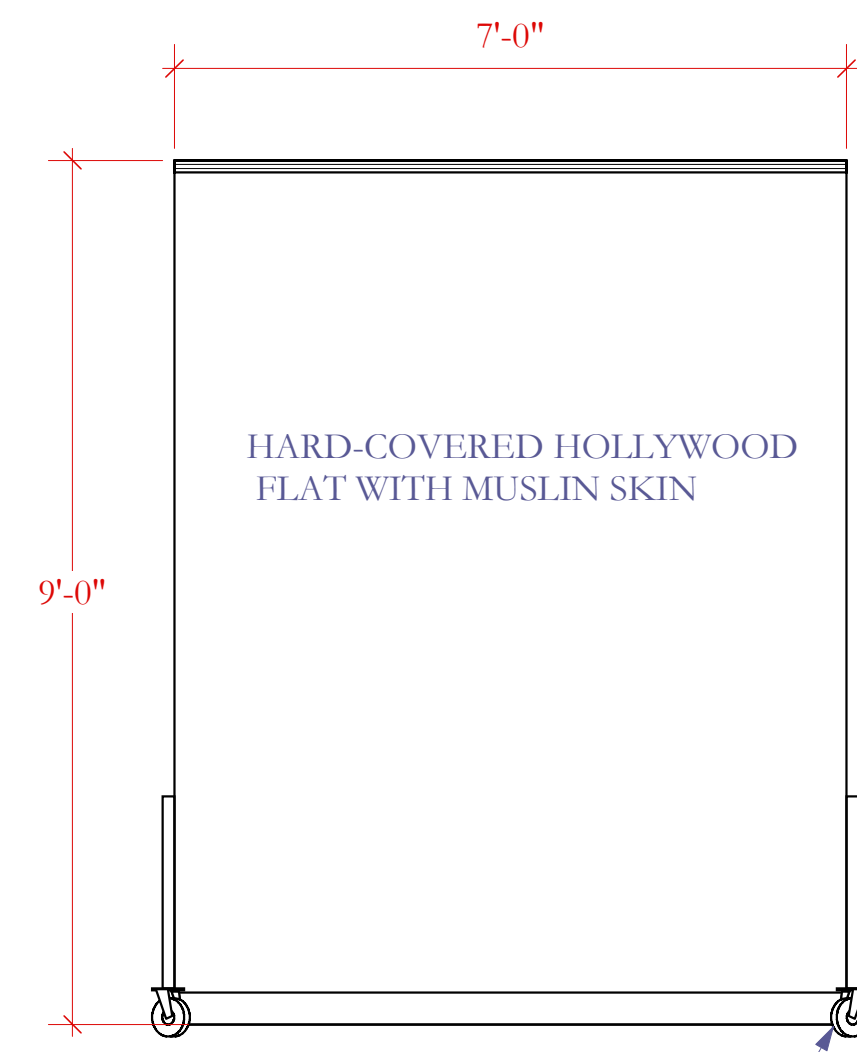

NOTICE THAT CASTERS ARE 1 1/2" BELOW BOTTOM OF WALL

1 WALL N
Scale: 1/2" = 1'-0"

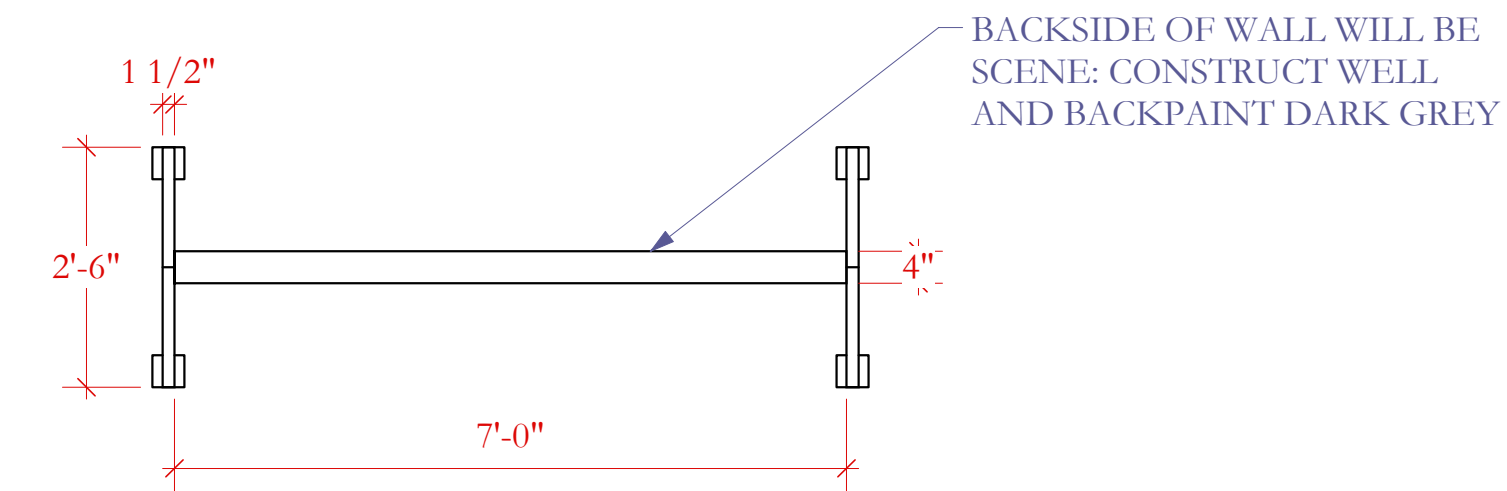

3 WALL N: PLAN VIEW
Scale: 1/2" = 1'-0"

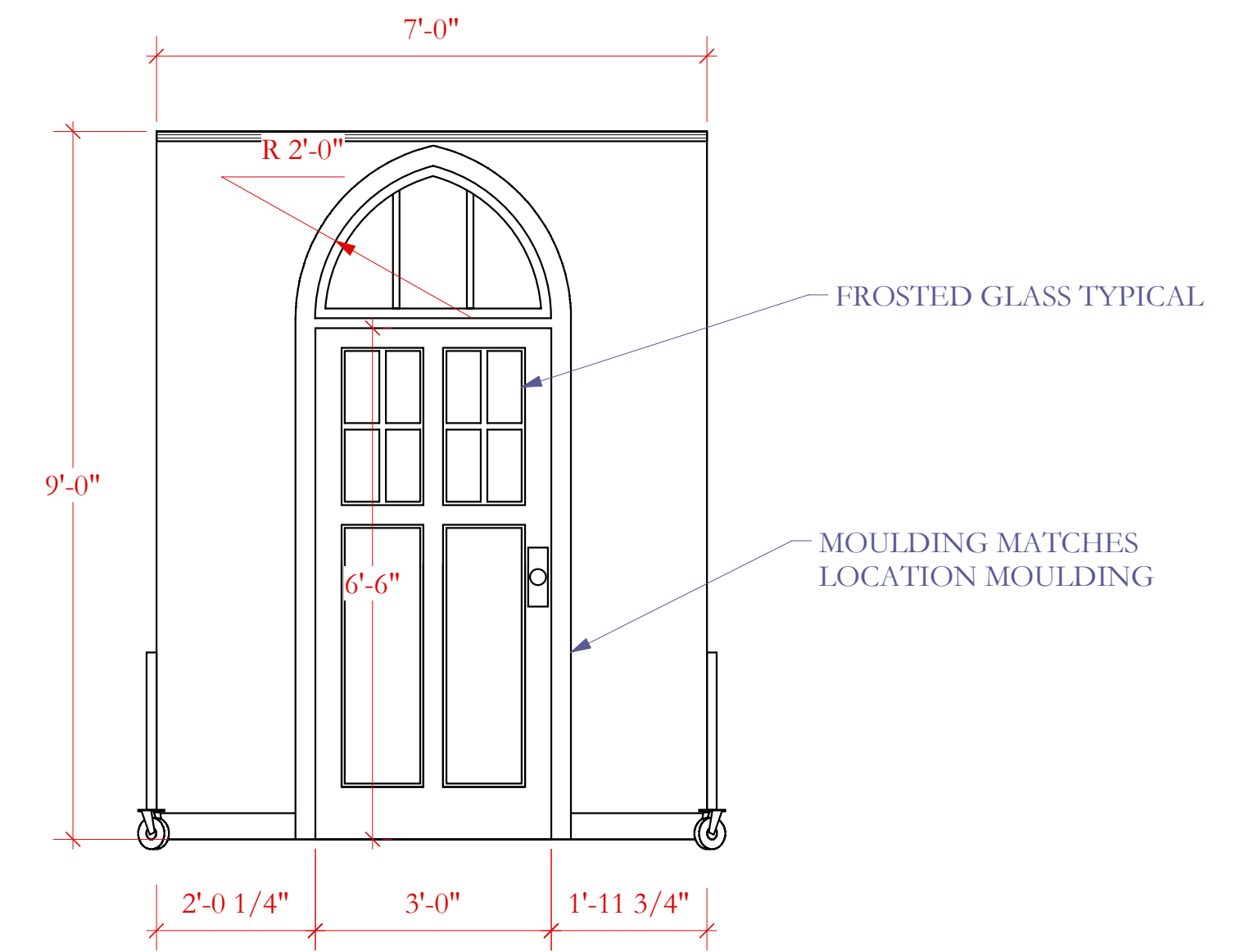

2 WALL O
Scale: 1/2" = 1'-0"

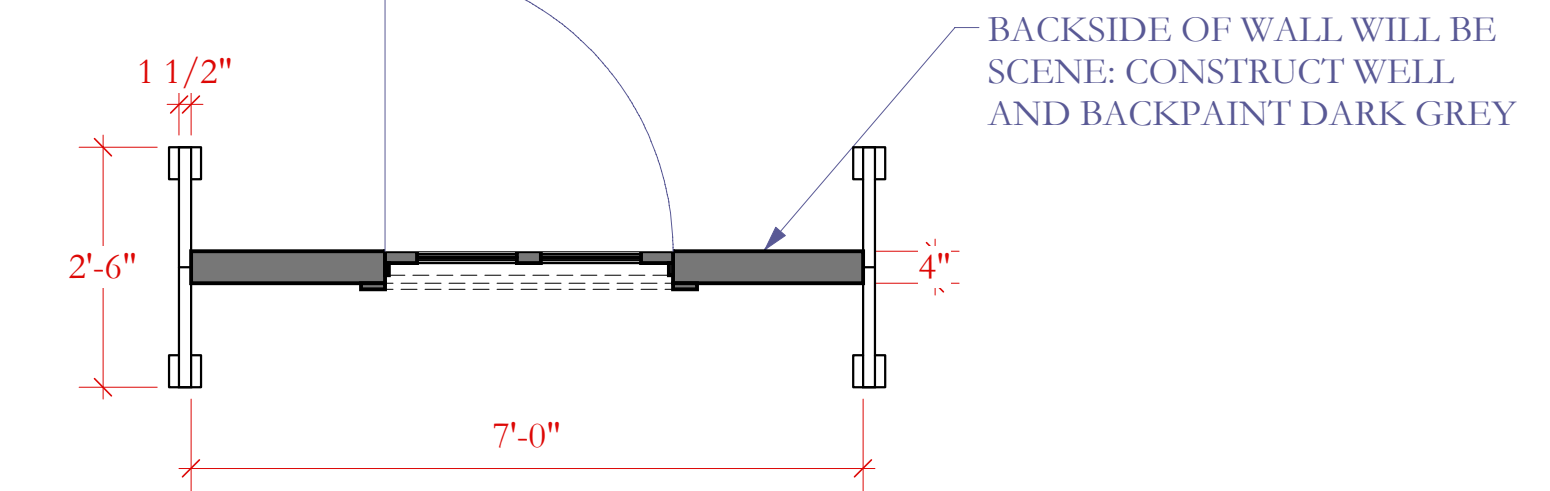

4 WALL O: PLAN VIEW
Scale: 1/2" = 1'-0"

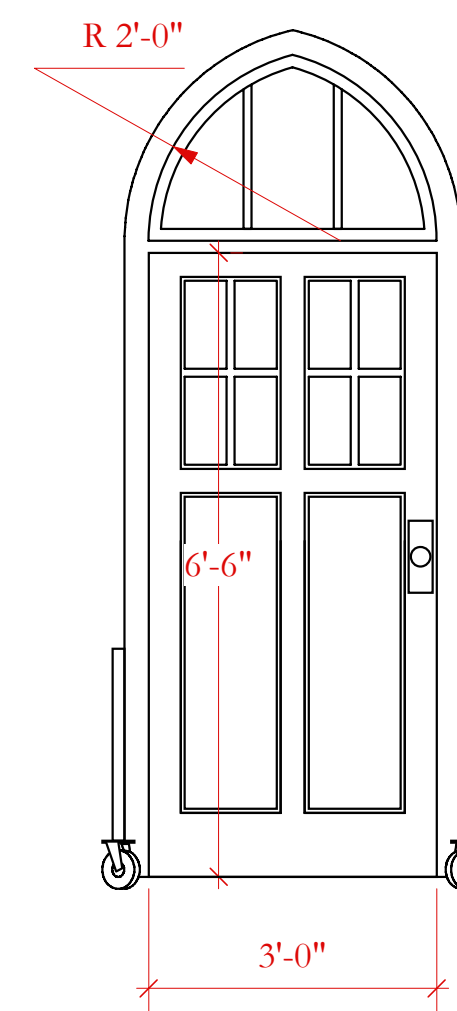

FREESTANDING ROLLING DOOR

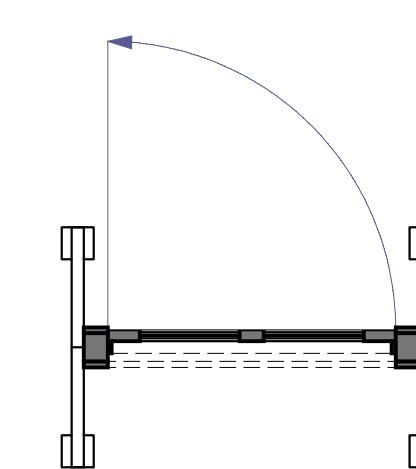

5 FREESTANDING DOOR
Scale: 1/2" = 1'-0"

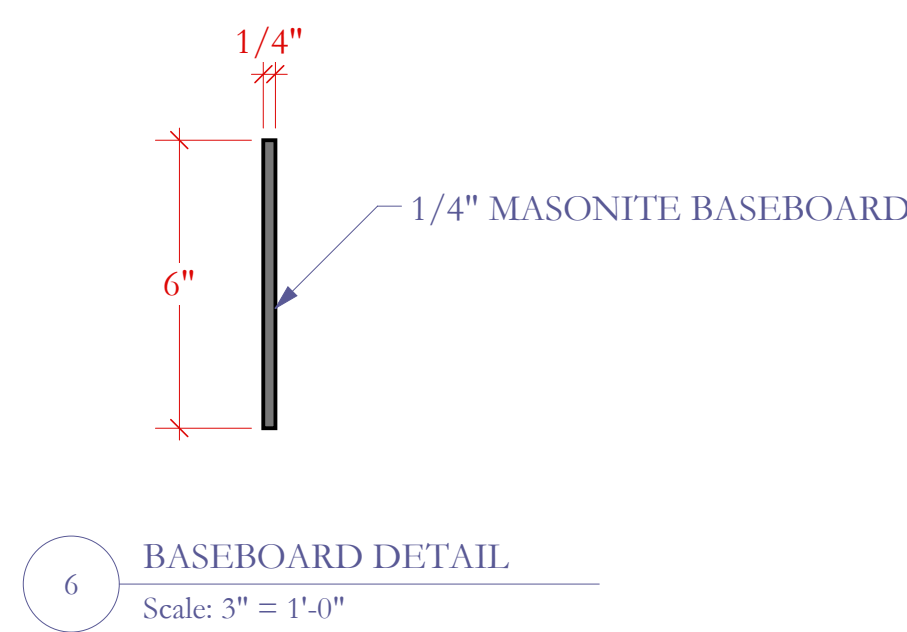

6 BASEBOARD DETAIL
Scale: 3" = 1'-0"

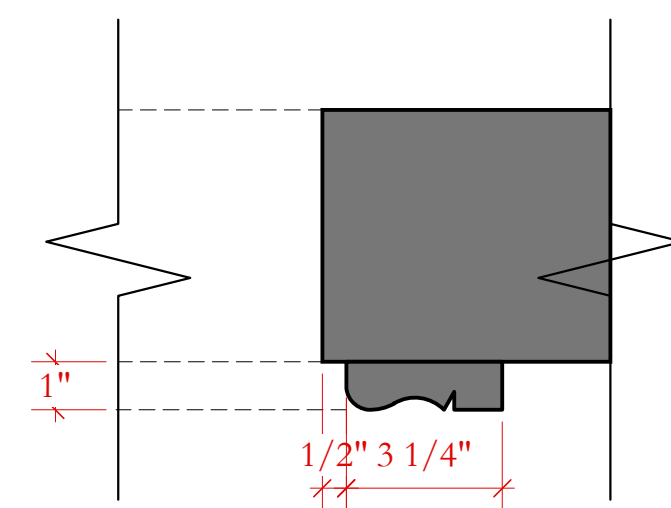

7 DOOR CASING DETAIL
Scale: 3" = 1'-0"

THE HISTORY BOYS
ROLLING WALLS

PITTSBURGH IRISH AND CLASSICAL THEATRE ARTISTIC DIRECTOR: ANDREW PAUL
DIRECTED BY ANDREW PAUL, PRODUCTION MANAGER: PHIL MADORE, TECHNICAL DIRECTOR: PAUL BISTRICAN

SCALE 1/2" = 1'-0"

DESIGNER: GIANNI DOWNS 412-779-7498
GIANNIDOWNS@GMAIL.COM
WWW.GIANNIDESIGNS.NET

DRAFTED: JULY 2, 2009
REVISED ON: JULY 7, 2009
JULY 16, 2009

PLATE:

6

OF 7

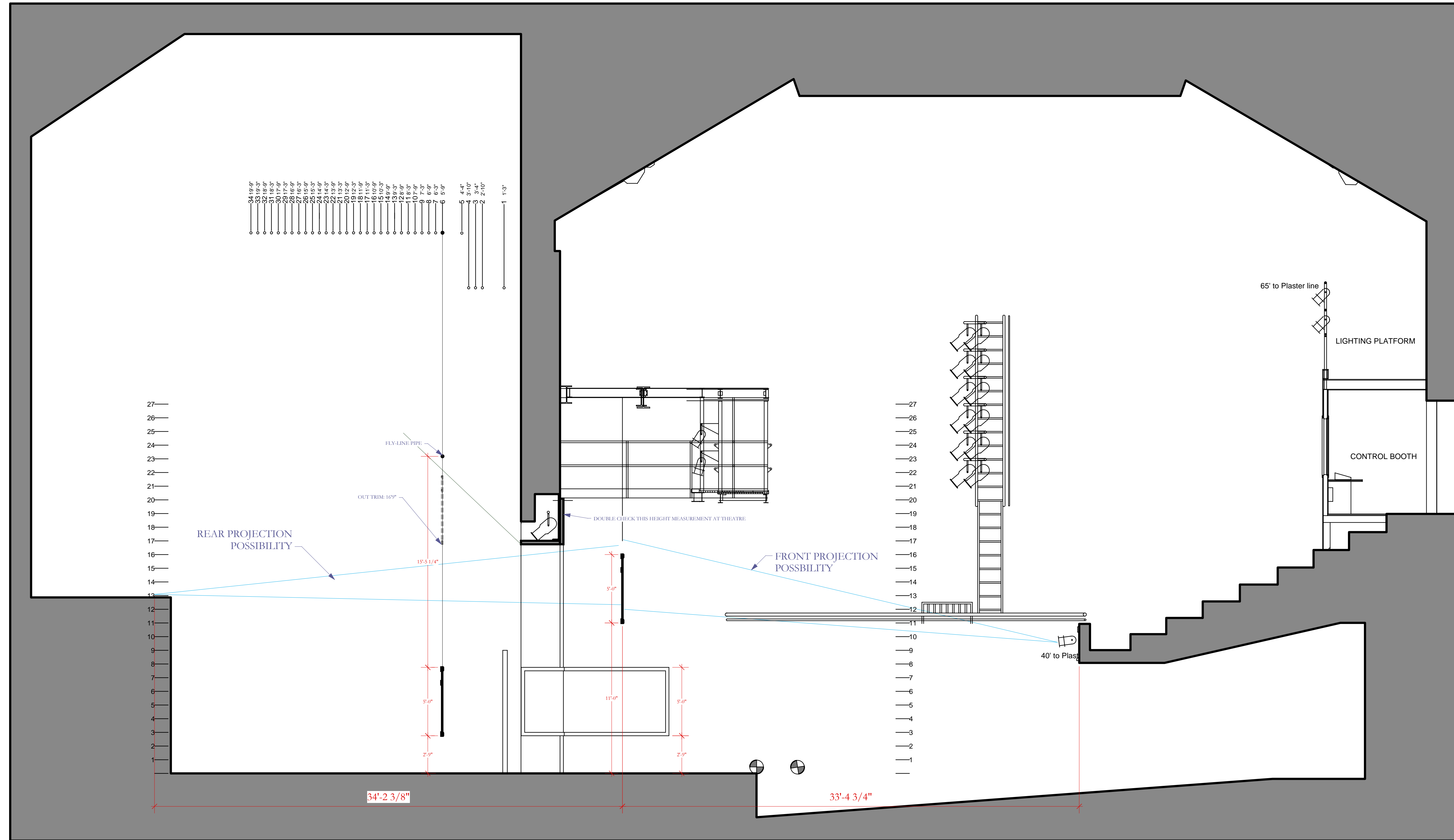

1 1/4" SECTION FOR PROJECTIONS
Scale: 1/4" = 1'-0"

THE HISTORY BOYS
PITTSBURGH IRISH AND CLASSICAL THEATRE, ARTISTIC DIRECTOR: ANDREW PAUL
DIRECTED BY ANDREW PAUL, PRODUCTION MANAGER: PHIL MADORE, TECHNICAL DIRECTOR: PAUL BISTRICAN

1/4" CENTERLINE SECTION

SCALE 1/4" = 1'-0"

DESIGNER: GIANNI DOWNS 412-779-7498
GIANNIDOWNS@GMAIL.COM
WWW.GIANNIDESIGNS.NET

DRAFTED: JULY 2, 2009
REVISED ON: JULY 7, 2009

PLATE:

7

OF 7